

A

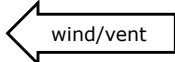

R

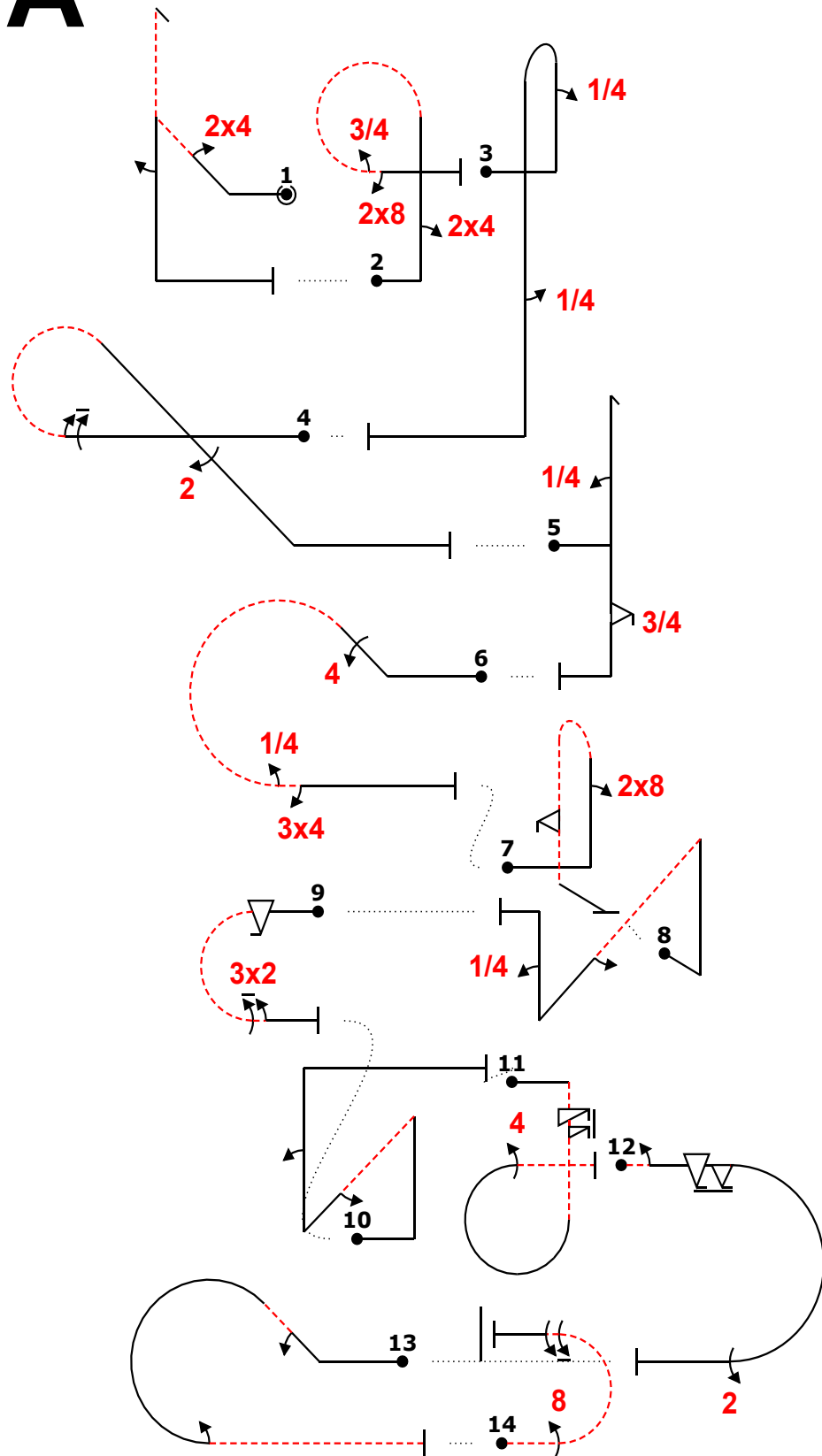

| Fig | Grade | Pos | Remarks |
|-----|-------|-----|---------|
| 1 | . | | |
| 2 | . | | |
| 3 | . | | |
| 4 | . | | |
| 5 | . | | |
| 6 | . | | |
| 7 | . | | |
| 8 | . | | |
| 9 | . | | |
| 10 | . | | |
| 11 | . | | |
| 12 | . | | |
| 13 | . | | |
| 14 | . | | |

Positioning

30

.

Too Low

Trg Violation

Too High

Wing Rocks

Interruptions

Disqual Fig

Insertions

Other(note...)

ed "0J" ,24dh,2..+~ (4,0) "@C" +,24rp3,8 "@L" +,4b... '4..+ (-1,0) "@F" .,6c... ,22+~ (4,0) "@E" '4''h'3f
 ' (-2,0) "@G" 7% ~~~~~ 44 ~~~rc4,34+ ~~~~~ (0,6) "@D" /,8pb,2f (1,1) "@L" n(...'2..)' 4+ (-10,0) "@B" fa
 32 (-1,16) "@L" 'n(2)2''+++ (-2,1) "@H" 6sirr44- "@A" 8% -'2' ,6fa22 (-14,0) "@L" 5% ~~~~~ 2'rc2-~ (2,0)
 "@I" -88m9

| Fig 1 J | K | Fig 2 C | K | Fig 3 L | K | Fig 4 F | K | Fig 5 E | K | Fig 6 G | K | Fig 7 D | K | Fig 8 L | K | Fig 9 B | K | Fig 10 L | K | Fig 11 H | K | Fig 12 A | K | Fig 13 L | K | Fig 14 I | K |
|---------|----|---------|----|---------|----|---------|----|---------|----|---------|----|----------|----|----------|----|---------|----|----------|----|----------|----|----------|---------|----------|----|----------|----|
| 5.3.2.1 | 24 | 8.6.4.1 | 14 | 8.4.1.1 | 13 | 8.5.7.1 | 12 | 5.2.1.1 | 17 | 8.5.3.1 | 12 | 8.4.3.1 | 15 | 1.3.12.1 | 21 | 7.2.2.3 | 8 | 1.3.12.1 | 21 | 8.6.3.3 | 13 | 7.2.1.4 | 6 | 8.5.4.1 | 11 | 7.2.1.2 | 8 |
| 9.4.2.2 | 7 | 9.4.1.2 | 9 | 9.1.1.1 | 6 | 9.1.3.6 | 10 | 9.1.1.1 | 6 | 9.4.2.4 | 13 | 9.8.1.1 | 7 | 9.1.4.2 | 4 | 9.9.3.4 | 11 | 9.1.4.2 | 4 | 9.11.1.6 | 3 | 9.1.3.2 | 4 | 9.1.2.2 | 6 | 9.8.3.4 | 15 |
| 9.1.5.2 | 4 | 9.1.3.3 | 6 | 9.1.5.1 | 2 | 9.2.4.4 | 9 | 9.9.5.3 | 11 | 9.1.3.1 | 2 | 9.9.10.2 | 13 | 9.1.1.1 | 6 | 9.2.3.6 | 12 | 9.1.1.2 | 8 | 9.4.3.4 | 11 | 9.9.3.6 | 14 | 9.1.3.2 | 4 | 9.1.3.8 | 12 |
| | 35 | 9.8.3.1 | 3 | | 6 | | 31 | | 34 | 9.4.3.3 | 8 | | 35 | | 6 | | 31 | | 6 | | 27 | | 9.2.3.4 | 9 | | 6 | 35 |
| | | | 32 | | | | | | | | | | | | | | | | | | | | | | | | |

Pilot:

A/C:

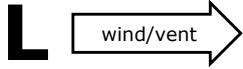

A

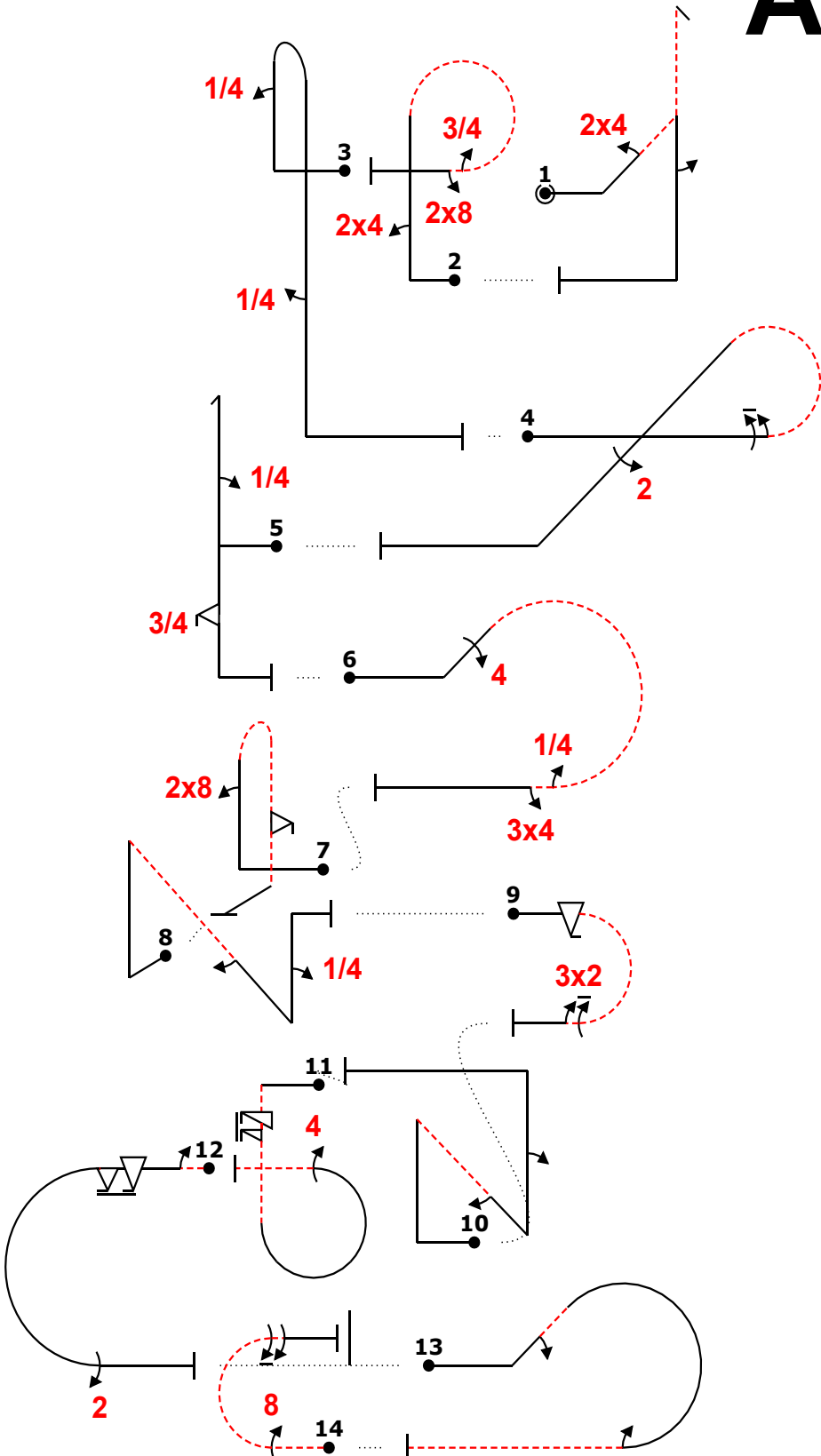

| Fig | Grade | Pos | Remarks |
|-----|-------|-----|---------|
| 1 | . | | |
| 2 | . | | |
| 3 | . | | |
| 4 | . | | |
| 5 | . | | |
| 6 | . | | |
| 7 | . | | |
| 8 | . | | |
| 9 | . | | |
| 10 | . | | |
| 11 | . | | |
| 12 | . | | |
| 13 | . | | |
| 14 | . | | |

Positioning
30

| | | | |
|---------------|--|----------------|--|
| Too Low | | Trg Violation | |
| Too High | | Wing Rocks | |
| Interruptions | | Disqual Fig | |
| Insertions | | Other(note...) | |

ed "@J",24dh,2..+~ (4,0) "@C" ^+,24rp3,8 "@L" ^+,4b... '4..+ (-1,0) "@F" ^.,6c...;22+~ (4,0) "@E" '4''h'3f
 ' (-2,0) "@G" %' ~~~~~ 44 ~~~rc4,34+ ~~~~~ (0,6) "@D" ^/,8pb,2f (1,1) "@L" n(...'2..)' 4+ (-10,0) "@B" fa
 32 (-1,16) "@L" ^n(2)2''+~ (-2,1) "@H" 6sirr44- "@A" 8% -'2',6fa22 (-14,0) "@L" 5% ~~~~~ 2''rc2-~ (2,0)
 "@I" ^-88m9

| Fig 1 J | K | Fig 2 C | K | Fig 3 L | K | Fig 4 F | K | Fig 5 E | K | Fig 6 G | K | Fig 7 D | K | Fig 8 L | K | Fig 9 B | K | Fig 10 L | K | Fig 11 H | K | Fig 12 A | K | Fig 13 L | K | Fig 14 I | K |
|---------|----|---------|----|---------|----|---------|----|---------|----|---------|----|----------|----|----------|----|---------|----|----------|----|----------|----|----------|----|----------|----|----------|----|
| 5.3.2.1 | 24 | 8.6.4.1 | 14 | 8.4.1.1 | 13 | 8.5.7.1 | 12 | 5.2.1.1 | 17 | 8.5.3.1 | 12 | 8.4.3.1 | 15 | 1.3.12.1 | 21 | 7.2.2.3 | 8 | 1.3.12.1 | 21 | 8.6.3.3 | 13 | 7.2.1.4 | 6 | 8.5.4.1 | 11 | 7.2.1.2 | 8 |
| 9.4.2.2 | 7 | 9.4.1.2 | 9 | 9.1.1.1 | 6 | 9.1.3.6 | 10 | 9.1.1.1 | 6 | 9.4.2.4 | 13 | 9.8.1.1 | 7 | 9.1.4.2 | 4 | 9.9.3.4 | 11 | 9.1.4.2 | 4 | 9.11.1.6 | 3 | 9.1.3.2 | 4 | 9.1.2.2 | 6 | 9.8.3.4 | 15 |
| 9.1.5.2 | 4 | 9.1.3.3 | 6 | 9.1.5.1 | 2 | 9.2.4.4 | 9 | 9.9.5.3 | 11 | 9.1.3.1 | 2 | 9.9.10.2 | 13 | 9.1.1.1 | 6 | 9.2.3.6 | 12 | 9.1.1.2 | 8 | 9.4.3.4 | 11 | 9.9.3.6 | 14 | 9.1.3.2 | 4 | 9.1.3.8 | 12 |
| | 35 | 9.8.3.1 | 3 | | 6 | | 31 | | 34 | 9.4.3.3 | 8 | | 35 | | 6 | | 31 | | 6 | | 27 | 9.2.3.4 | 9 | | 6 | | 35 |

Pilot:

A/C:

B

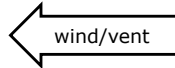

R

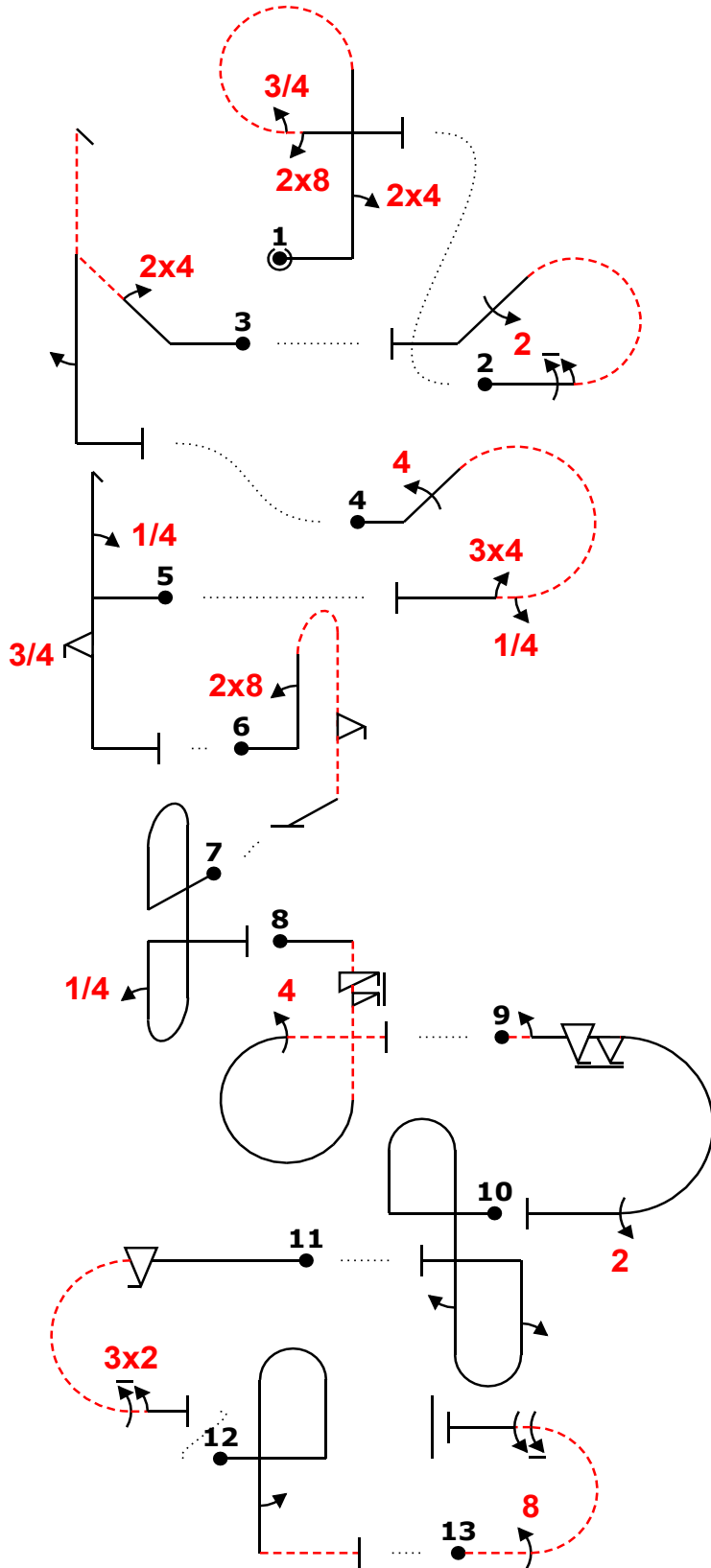

| Fig | Grade | Pos | Remarks |
|-----|-------|-----|---------|
| 1 | . | | |
| 2 | . | | |
| 3 | . | | |
| 4 | . | | |
| 5 | . | | |
| 6 | . | | |
| 7 | . | | |
| 8 | . | | |
| 9 | . | | |
| 10 | . | | |
| 11 | . | | |
| 12 | . | | |
| 13 | . | | |

Positioning **30** .

| | | | |
|---------------|--|----------------|--|
| Too Low | | Trg Violation | |
| Too High | | Wing Rocks | |
| Interruptions | | Disqual Fig | |
| Insertions | | Other(note...) | |

"@C" ,24rp3,8 (1,16) "@F"6c22..... (-5,0) "@J" ,24dh.,2. (9,5) 2% "@G"44" rc4,34+
 (-10,0) "@E" ,4h.,3f., (1,0) "@D"8pb2f+ (-1,1) "@L"bb(4> "@H" 6sirr44- (3,0) 4% "@A" ->
2,6fa22 "@L"bb(2^),2 (-3,0) 2% "@B"fa32+ (-2,3) "@L" /...b'12^- (2,0) "@I" -88m9

| Fig 1 C | K | Fig 2 F | K | Fig 3 J | K | Fig 4 G | K | Fig 5 E | K | Fig 6 D | K | Fig 7 L | K | Fig 8 H | K | Fig 9 A | K | Fig 10 L | K | Fig 11 B | K | Fig 12 L | K | Fig 13 I | K |
|---------|-----------|---------|-----------|---------|-----------|---------|-----------|---------|-----------|----------|-----------|---------|----------|----------|-----------|---------|-----------|----------|----------|----------|-----------|----------|----------|----------|-----------|
| 8.6.4.1 | 14 | 8.5.7.1 | 12 | 5.3.2.1 | 24 | 8.5.3.1 | 12 | 5.2.1.1 | 17 | 8.4.3.1 | 15 | 8.8.2.1 | 19 | 8.6.3.3 | 13 | 7.2.1.4 | 6 | 8.8.2.1 | 19 | 7.2.2.3 | 8 | 8.4.2.1 | 14 | 7.2.1.2 | 8 |
| 9.4.1.2 | 9 | 9.1.3.6 | 10 | 9.4.2.2 | 7 | 9.4.2.4 | 13 | 9.1.1.1 | 6 | 9.8.1.1 | 7 | 9.1.1.1 | 6 | 9.11.1.6 | 3 | 9.1.3.2 | 4 | 9.1.5.2 | 4 | 9.9.3.4 | 11 | 9.1.5.2 | 4 | 9.8.3.4 | 15 |
| 9.1.3.3 | 6 | 9.2.4.4 | 9 | 9.1.5.2 | 4 | 9.1.3.1 | 2 | 9.9.5.3 | 11 | 9.9.10.2 | 13 | | | 9.4.3.4 | 11 | 9.9.3.6 | 14 | 9.1.1.2 | 8 | 9.2.3.6 | 12 | | | 9.1.3.8 | 12 |
| 9.8.3.1 | 3 | | | | | 9.4.3.3 | 8 | | | | | | | | | 9.2.3.4 | 9 | | | | | | | | |
| | 32 | | 31 | | 35 | | 35 | | 34 | | 35 | | 8 | | 27 | | 33 | | 8 | | 31 | | 8 | | 35 |

Pilot:

A/C:

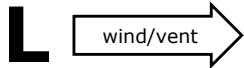

B

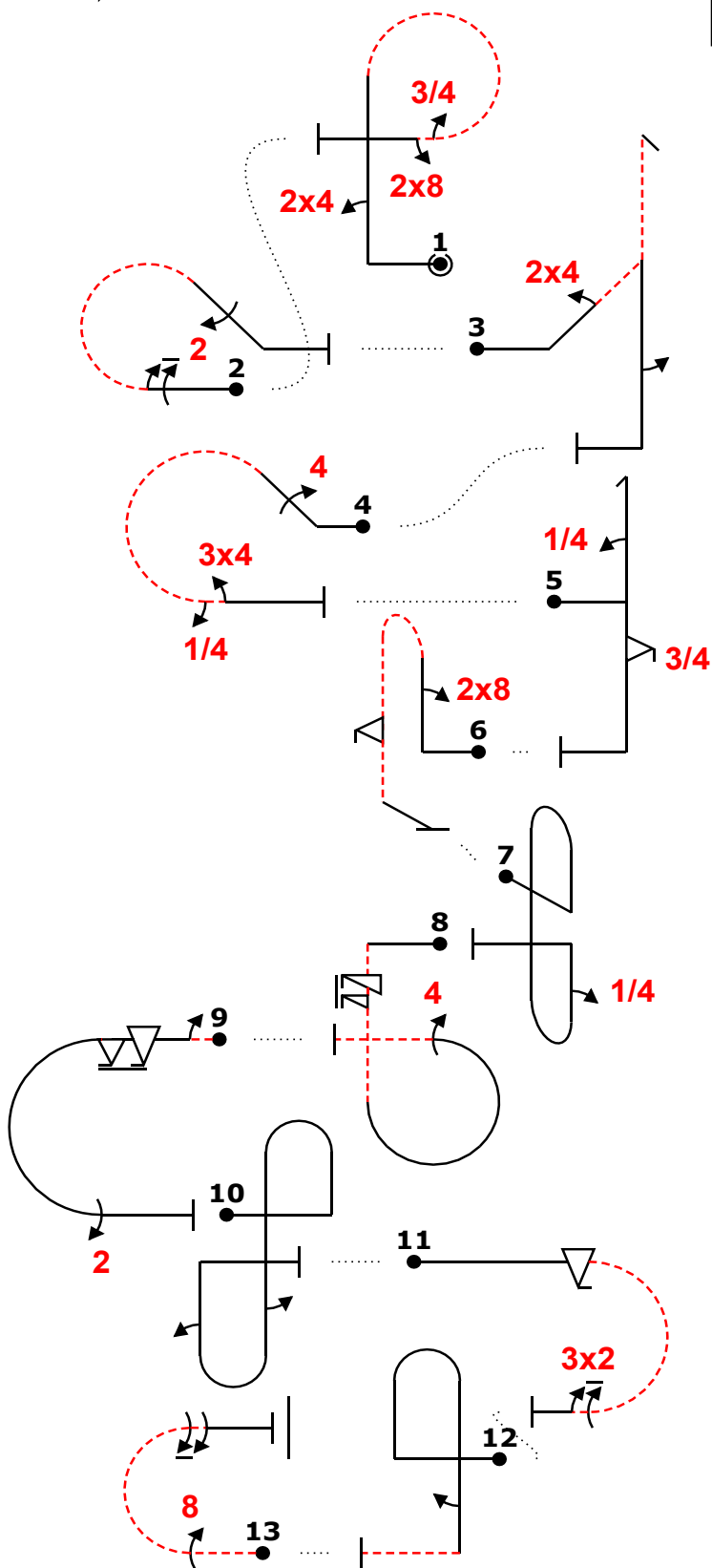

| Fig | Grade | Pos | Remarks |
|-----|-------|-----|---------|
| 1 | . | | |
| 2 | . | | |
| 3 | . | | |
| 4 | . | | |
| 5 | . | | |
| 6 | . | | |
| 7 | . | | |
| 8 | . | | |
| 9 | . | | |
| 10 | . | | |
| 11 | . | | |
| 12 | . | | |
| 13 | . | | |

Positioning
30 .

| | | | |
|---------------|--|----------------|--|
| Too Low | | Trg Violation | |
| Too High | | Wing Rocks | |
| Interruptions | | Disqual Fig | |
| Insertions | | Other(note...) | |

"@C" ,24rp3,8 (1,16) "@F"6c22..... (-5,0) "@J" ,24dh.,2. (9,5) 2% "@G"44" rc4,34+
 (-10,0) "@E" ,4h",3f. (1,0) "@D"8pb2f+ (-1,1) "@L"bb(.....)4> "@H" 6sirn44- (3,0) 4% "@A" ->
2,6fa22 "@L"bb(,2"),2 (-3,0) 2% "@B"fa32+ (-2,3) "@L" /.....b'1'2- (2,0) "@I" -88m9

| Fig 1 C | K | Fig 2 F | K | Fig 3 J | K | Fig 4 G | K | Fig 5 E | K | Fig 6 D | K | Fig 7 L | K | Fig 8 H | K | Fig 9 A | K | Fig 10 L | K | Fig 11 B | K | Fig 12 L | K | Fig 13 I | K |
|---------|-----------|---------|-----------|---------|-----------|---------|-----------|---------|-----------|----------|-----------|---------|----------|---------|-----------|---------|-----------|----------|----------|----------|-----------|----------|----------|----------|-----------|
| 8.6.4.1 | 14 | 8.5.7.1 | 12 | 5.3.2.1 | 24 | 8.5.3.1 | 12 | 5.2.1.1 | 17 | 8.4.3.1 | 15 | 8.8.2.1 | 19 | 8.6.3.3 | 13 | 7.2.1.4 | 6 | 8.8.2.1 | 19 | 7.2.2.3 | 8 | 8.4.2.1 | 14 | 7.2.1.2 | 8 |
| 9.4.1.2 | 9 | 9.1.3.6 | 10 | 9.4.2.2 | 7 | 9.4.2.4 | 13 | 9.1.1.1 | 6 | 9.8.1.1 | 7 | 9.1.1.1 | 6 | 9.1.1.6 | 3 | 9.1.3.2 | 4 | 9.1.5.2 | 4 | 9.9.3.4 | 11 | 9.1.5.2 | 4 | 9.8.3.4 | 15 |
| 9.1.3.3 | 6 | 9.2.4.4 | 9 | 9.1.5.2 | 4 | 9.1.3.1 | 2 | 9.9.5.3 | 11 | 9.9.10.2 | 13 | | | 9.4.3.4 | 11 | 9.9.3.6 | 14 | 9.1.1.2 | 8 | 9.2.3.6 | 12 | | | 9.1.3.8 | 12 |
| 9.8.3.1 | 3 | | | | | 9.4.3.3 | 8 | | | | | | | | | 9.2.3.4 | 9 | | | | | | | | |
| | 32 | | 31 | | 35 | | 35 | | 34 | | 35 | | 8 | | 27 | | 33 | | 8 | | 31 | | 8 | | 35 |

Pilot:

A/C:

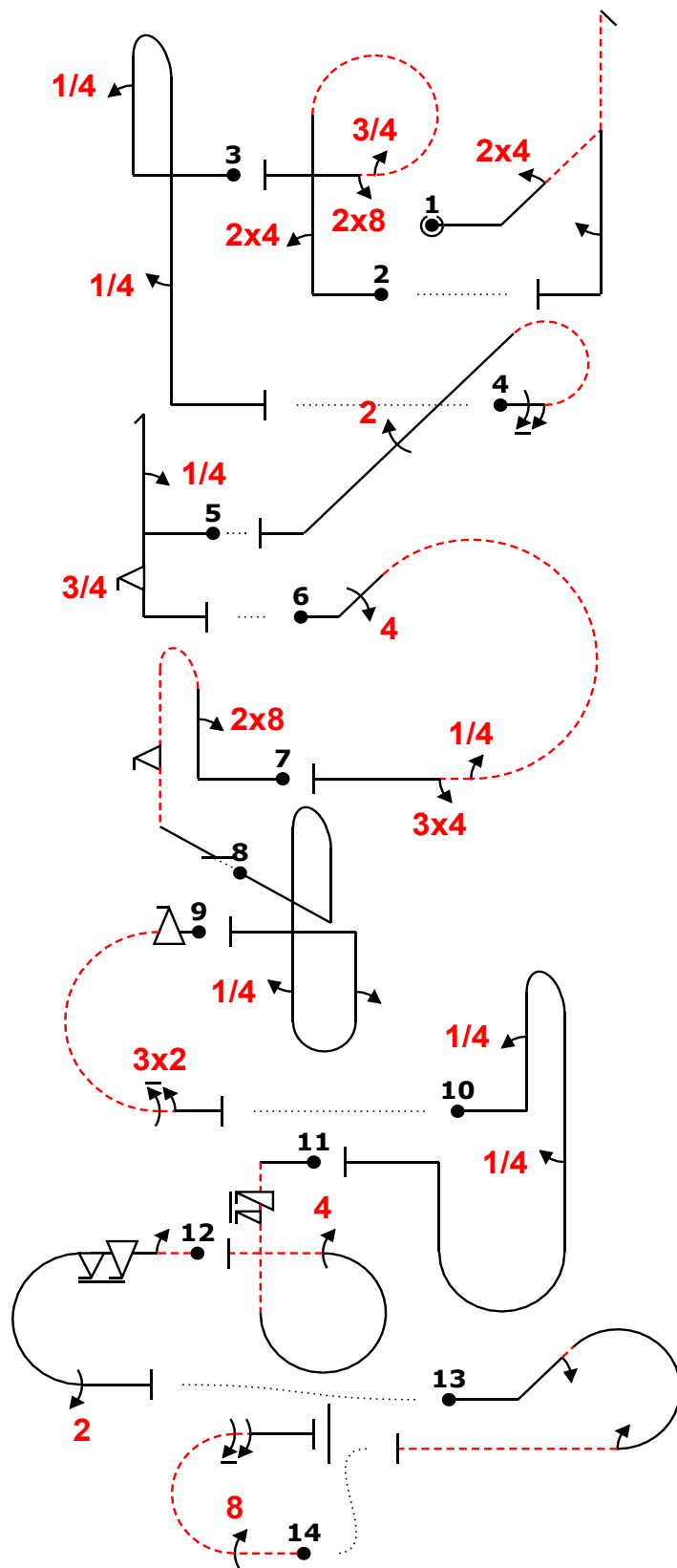
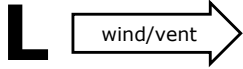

| Fig | Grade | Pos | Remarks |
|-----|-------|-----|---------|
| 1 | . | | |
| 2 | . | | |
| 3 | . | | |
| 4 | . | | |
| 5 | . | | |
| 6 | . | | |
| 7 | . | | |
| 8 | . | | |
| 9 | . | | |
| 10 | . | | |
| 11 | . | | |
| 12 | . | | |
| 13 | . | | |
| 14 | . | | |

| | |
|-------------|---|
| Positioning | . |
| 30 | . |

| | | | |
|---------------|--|----------------|--|
| Too Low | | Trg Violation | |
| Too High | | Wing Rocks | |
| Interruptions | | Disqual Fig | |
| Insertions | | Other(note...) | |

ed "@J" ,24'dh.2'' (6,0) "@C" ,24rp3,8 "@L" ,4b...''4.' (-11,0) -3% "@F"6c....22. (-1,0) "@E" 4h^3 f (-2,0) 10% "@G"44''rc4,34+ "@D" '+' 8pb2f (2,-1) "@L" + bb('4'')2~> 5% "@B"f a,32+'' (-11,0) "@L"4' 'bB(4'') "@H" '+6s1rp44- 1% "@A" -''2''.....6fa22 (-15,1) "@L"2''rc2- (2,7) "@I" -88m9

| Fig 1 J | K | Fig 2 C | K | Fig 3 L | K | Fig 4 F | K | Fig 5 E | K | Fig 6 G | K | Fig 7 D | K | Fig 8 L | K | Fig 9 B | K | Fig 10 L | K | Fig 11 H | K | Fig 12 A | K | Fig 13 L | K | Fig 14 I | K |
|---------|----|---------|----|---------|----|---------|----|---------|----|---------|----|----------|----|---------|----|---------|----|----------|----|----------|----|----------|---------|----------|----|----------|----|
| 5.3.2.1 | 24 | 8.6.4.1 | 14 | 8.4.1.1 | 13 | 8.5.7.1 | 12 | 5.2.1.1 | 17 | 8.5.3.1 | 12 | 8.4.3.1 | 15 | 8.8.2.1 | 19 | 7.2.2.3 | 8 | 8.8.2.1 | 19 | 8.6.3.3 | 13 | 7.2.1.4 | 6 | 8.5.4.1 | 11 | 7.2.1.2 | 8 |
| 9.4.2.2 | 7 | 9.4.1.2 | 9 | 9.1.1.1 | 6 | 9.1.3.6 | 10 | 9.1.1.1 | 6 | 9.4.2.4 | 13 | 9.8.1.1 | 7 | 9.1.5.1 | 2 | 9.9.3.4 | 11 | 9.1.1.1 | 6 | 9.11.1.6 | 3 | 9.1.3.2 | 4 | 9.1.2.2 | 6 | 9.8.3.4 | 15 |
| 9.1.5.2 | 4 | 9.1.3.3 | 6 | 9.1.5.1 | 2 | 9.2.4.4 | 9 | 9.9.5.3 | 11 | 9.1.3.1 | 2 | 9.9.10.2 | 13 | 9.1.1.2 | 8 | 9.2.3.6 | 12 | 9.1.5.1 | 2 | 9.4.3.4 | 11 | 9.9.3.6 | 14 | 9.1.3.2 | 4 | 9.1.3.8 | 12 |
| | 35 | 9.8.3.1 | 3 | | 6 | | 31 | | 34 | 9.4.3.3 | 8 | | 35 | | 6 | | 31 | | 6 | | 27 | | 9.2.3.4 | 9 | | 6 | 35 |
| | | | 32 | | | | | | | | | | | | | | | | | | | | | | | | |

Pilot:

A/C:

D

wind/vent ← **R**

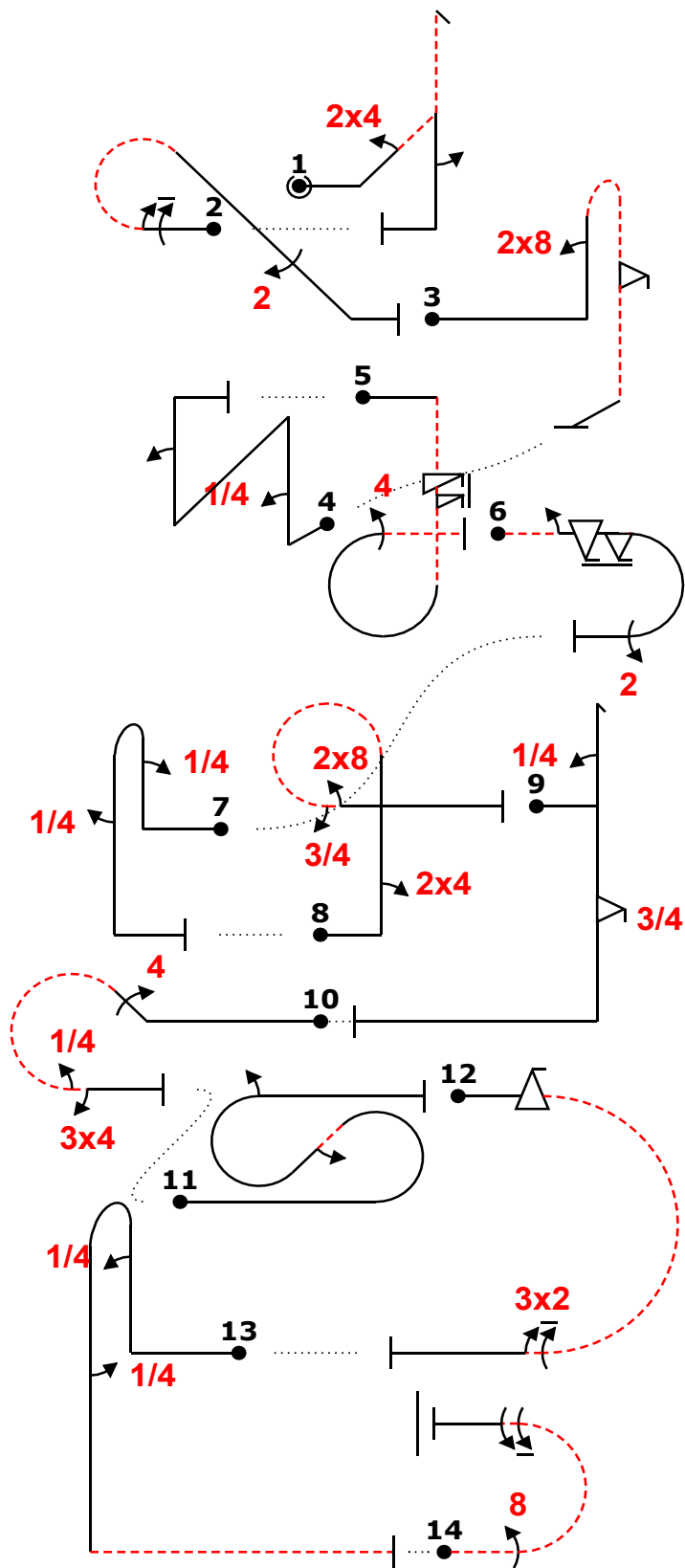

| Fig | Grade | Pos | Remarks |
|-----|-------|-----|---------|
| 1 | . | | |
| 2 | . | | |
| 3 | . | | |
| 4 | . | | |
| 5 | . | | |
| 6 | . | | |
| 7 | . | | |
| 8 | . | | |
| 9 | . | | |
| 10 | . | | |
| 11 | . | | |
| 12 | . | | |
| 13 | . | | |
| 14 | . | | |

Positioning **30** .

| | | | |
|---------------|--|----------------|--|
| Too Low | | Trg Violation | |
| Too High | | Wing Rocks | |
| Interruptions | | Disqual Fig | |
| Insertions | | Other(note...) | |

-2% "0J" 24dh2. (-6,0) -3% "0F" ,6c... ,22" -2% "0D" ~~~+8pb2f.' ' (-11,4) -2% "0L" 4pn2 (4,0) -2% "0H" ~. '6sirr44- -2% "0A" -2,6fa22 (-17,12) "0L" -3% ,4b,4.. (4,0) -2% "0C" ,24" rp,3,8+-2% "0E" 4h. '3f..++++~ (2,0) -1% "0G" ~++ ,44" rnc4,34+ (-3,7) -3% "0L" ac(2)2+ 10% "0B" ``fa,32 (-5,0) "0L" 4b' 4.. ---- (-1,0) "0I" -88m9

| Fig 1 J | K | Fig 2 F | K | Fig 3 D | K | Fig 4 L | K | Fig 5 H | K | Fig 6 A | K | Fig 7 L | K | Fig 8 C | K | Fig 9 E | K | Fig 10 G | K | Fig 11 L | K | Fig 12 B | K | Fig 13 L | K | Fig 14 I | K |
|---------|-----------|---------|-----------|----------|-----------|----------|----------|----------|-----------|---------|-----------|---------|----------|---------|-----------|---------|-----------|----------|-----------|----------|----------|----------|-----------|----------|----------|----------|-----------|
| 5.3.2.1 | 24 | 8.5.7.1 | 12 | 8.4.3.1 | 15 | 1.3.13.1 | 22 | 8.6.3.3 | 13 | 7.2.1.4 | 6 | 8.4.1.1 | 13 | 8.6.4.1 | 14 | 5.2.1.1 | 17 | 8.5.3.1 | 12 | 7.5.7.1 | 15 | 7.2.2.3 | 8 | 8.4.2.1 | 14 | 7.2.1.2 | 8 |
| 9.4.2.2 | 7 | 9.1.3.6 | 10 | 9.8.1.1 | 7 | 9.1.1.1 | 6 | 9.11.1.6 | 3 | 9.1.3.2 | 4 | 9.1.1.1 | 6 | 9.4.1.2 | 9 | 9.1.1.1 | 6 | 9.4.2.4 | 13 | 9.1.4.2 | 4 | 9.9.3.4 | 11 | 9.1.1.1 | 6 | 9.8.3.4 | 15 |
| 9.1.5.2 | 4 | 9.2.4.4 | 9 | 9.9.10.2 | 13 | 9.1.1.2 | 8 | 9.4.3.4 | 11 | 9.9.3.6 | 14 | 9.1.5.1 | 2 | 9.1.3.3 | 6 | 9.9.5.3 | 11 | 9.1.3.1 | 2 | 9.1.3.2 | 4 | 9.2.3.6 | 12 | 9.1.5.1 | 2 | 9.1.3.8 | 12 |
| | 35 | | 31 | | 35 | | 6 | | 27 | | 33 | | 6 | | 32 | | 34 | | 35 | | 6 | | 31 | | 6 | | 35 |

Pilot:

A/C:

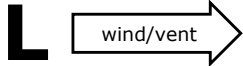

D

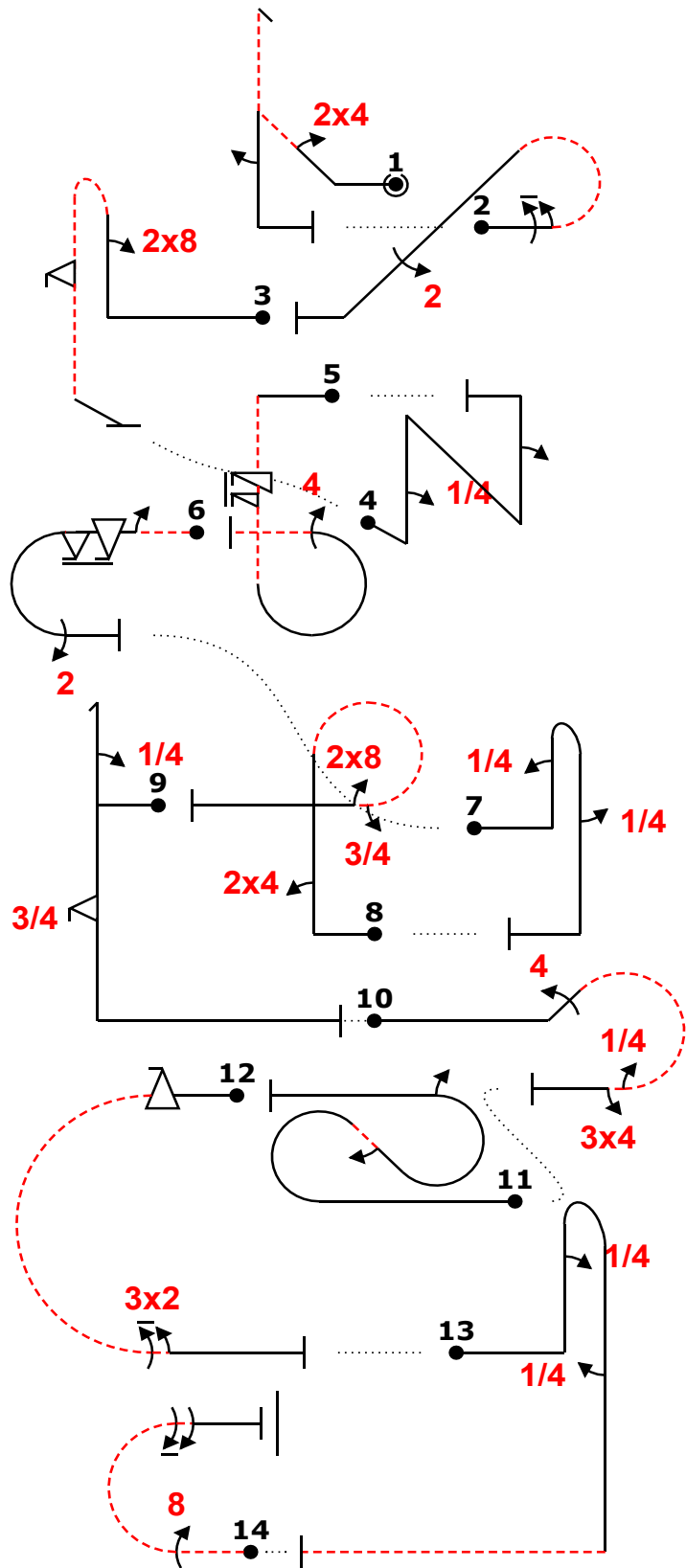

| Fig | Grade | Pos | Remarks |
|-----|-------|-----|---------|
| 1 | . | | |
| 2 | . | | |
| 3 | . | | |
| 4 | . | | |
| 5 | . | | |
| 6 | . | | |
| 7 | . | | |
| 8 | . | | |
| 9 | . | | |
| 10 | . | | |
| 11 | . | | |
| 12 | . | | |
| 13 | . | | |
| 14 | . | | |

| | | |
|-------------|----|---|
| Positioning | 30 | . |
|-------------|----|---|

| | | | |
|---------------|--|----------------|--|
| Too Low | | Trg Violation | |
| Too High | | Wing Rocks | |
| Interruptions | | Disqual Fig | |
| Insertions | | Other(note...) | |

-2% "@J" 24dh2. (-6,0) -3% "@F" ... ,6c... ,22" -2% "@D" ~~~+8pb2f.' (-11,4) -2% "@L" 4pn2 (4,0) -2% "@H" ~.6sirp44- -2% "@A" -2,6fa22 (-17,12) "@L" -3% ,4b,4.. (4,0) -2% "@C" ,24" 'rp,3,8+-2% "@E" 4h.'3f..++++~ (2,0) -1% "@G" ~++ ,44" 'rc4,34+ (3,7) -3% "@L" ac(2)2+ 10% "@B" 'fa,32 (-5,0) "@L" 4b' 4..----- (-1,0) "@I" -88m9

| Fig 1 J | K | Fig 2 F | K | Fig 3 D | K | Fig 4 L | K | Fig 5 H | K | Fig 6 A | K | Fig 7 L | K | Fig 8 C | K | Fig 9 E | K | Fig 10 G | K | Fig 11 L | K | Fig 12 B | K | Fig 13 L | K | Fig 14 I | K |
|---------|----|---------|----|----------|----|----------|----|----------|----|---------|----|---------|----|---------|----|---------|----|----------|----|----------|----|----------|----|----------|----|----------|----|
| 5.3.2.1 | 24 | 8.5.7.1 | 12 | 8.4.3.1 | 15 | 1.3.13.1 | 22 | 8.6.3.3 | 13 | 7.2.1.4 | 6 | 8.4.1.1 | 13 | 8.6.4.1 | 14 | 5.2.1.1 | 17 | 8.5.3.1 | 12 | 7.5.7.1 | 15 | 7.2.2.3 | 8 | 8.4.2.1 | 14 | 7.2.1.2 | 8 |
| 9.4.2.2 | 7 | 9.1.3.6 | 10 | 9.8.1.1 | 7 | 9.1.1.1 | 6 | 9.11.1.6 | 3 | 9.1.3.2 | 4 | 9.1.1.1 | 6 | 9.4.1.2 | 9 | 9.1.1.1 | 6 | 9.4.2.4 | 13 | 9.1.4.2 | 4 | 9.9.3.4 | 11 | 9.1.1.1 | 6 | 9.8.3.4 | 15 |
| 9.1.5.2 | 4 | 9.2.4.4 | 9 | 9.9.10.2 | 13 | 9.1.1.2 | 8 | 9.4.3.4 | 11 | 9.9.3.6 | 14 | 9.1.5.1 | 2 | 9.1.3.3 | 6 | 9.9.5.3 | 11 | 9.1.3.1 | 2 | 9.1.3.2 | 4 | 9.2.3.6 | 12 | 9.1.5.1 | 2 | 9.1.3.8 | 12 |
| | 35 | | 31 | | 35 | | 6 | | 27 | | 33 | | 6 | | 32 | | 34 | | 35 | | 6 | | 31 | | 6 | | 35 |

Pilot:

A/C:

E

wind/vent ← **R**

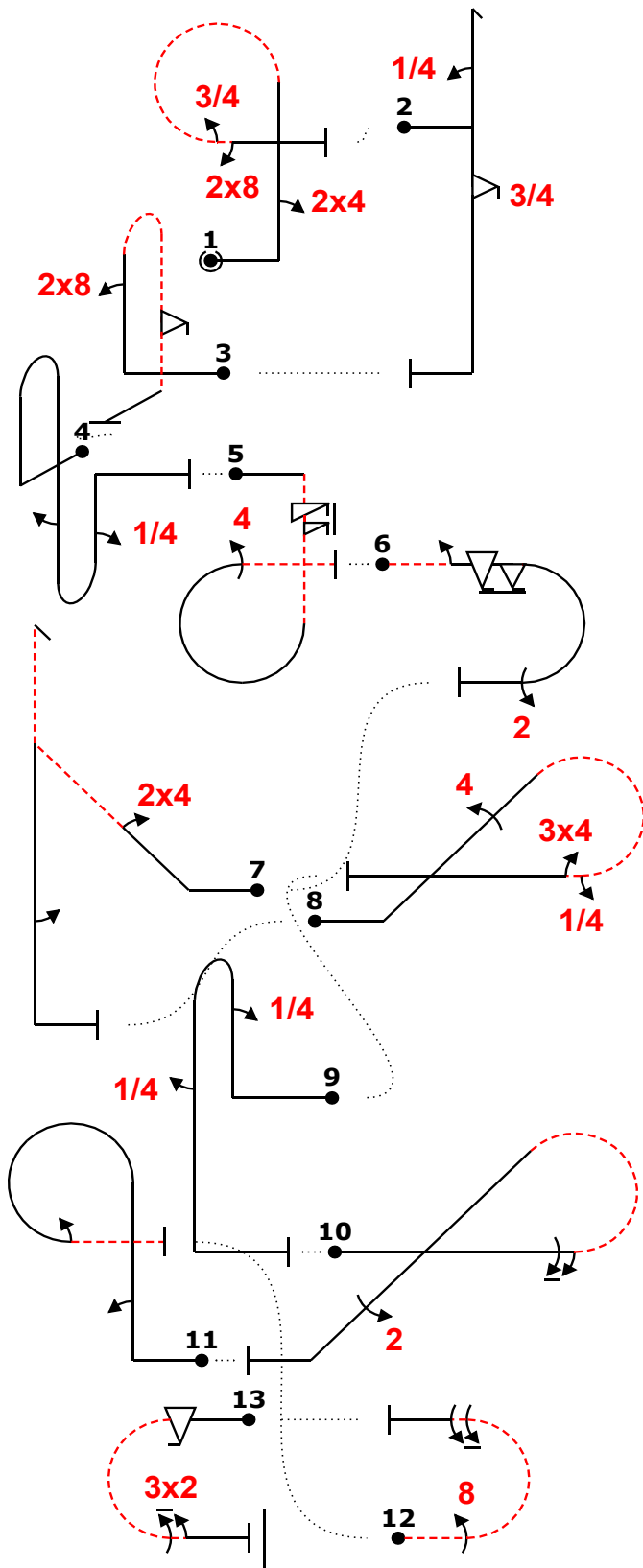

| Fig | Grade | Pos | Remarks |
|-----|-------|-----|---------|
| 1 | . | | |
| 2 | . | | |
| 3 | . | | |
| 4 | . | | |
| 5 | . | | |
| 6 | . | | |
| 7 | . | | |
| 8 | . | | |
| 9 | . | | |
| 10 | . | | |
| 11 | . | | |
| 12 | . | | |
| 13 | . | | |

Positioning **30** .

| | | | |
|---------------|--|----------------|--|
| Too Low | | Trg Violation | |
| Too High | | Wing Rocks | |
| Interruptions | | Disqual Fig | |
| Insertions | | Other(note...) | |

"@C" ,24rp3,28 (1,-1) "@E" 4h3f... (-8,0) "@D" 28pb2f (2,0) "@L" bb(,2),4 (-1,0) "@H" 6sirr44- (-1,0) "@A" -2, 6fa22 (-9,14) "@J" ' ,24. 'dh... '2... ' (10,-7) "@G" 44rc4,34 (3,15) "@L" ,4b,4... (-1,0) "@F" ,6c....22... (1,0) "@L" 2rp2- (11,20) "@I" -88m9 (-5,0) "@B" fa32

| Fig 1 C | K | Fig 2 E | K | Fig 3 D | K | Fig 4 L | K | Fig 5 H | K | Fig 6 A | K | Fig 7 J | K | Fig 8 G | K | Fig 9 L | K | Fig 10 F | K | Fig 11 L | K | Fig 12 I | K | Fig 13 B | K |
|---------|-----------|---------|-----------|----------|-----------|---------|----------|---------|-----------|---------|-----------|---------|-----------|---------|-----------|---------|----------|----------|-----------|----------|----------|----------|-----------|----------|-----------|
| 8.6.4.1 | 14 | 5.2.1.1 | 17 | 8.4.3.1 | 15 | 8.8.2.1 | 19 | 8.6.3.3 | 13 | 7.2.1.4 | 6 | 5.3.2.1 | 24 | 8.5.3.1 | 12 | 8.4.1.1 | 13 | 8.5.7.1 | 12 | 8.6.2.1 | 12 | 7.2.1.2 | 8 | 7.2.2.3 | 8 |
| 9.4.1.2 | 9 | 9.1.1.1 | 6 | 9.8.1.1 | 7 | 9.1.5.2 | 4 | 9.1.1.6 | 3 | 9.1.3.2 | 4 | 9.4.2.2 | 7 | 9.4.2.4 | 13 | 9.1.1.1 | 6 | 9.1.3.6 | 10 | 9.1.1.2 | 8 | 9.8.3.4 | 15 | 9.9.3.4 | 11 |
| 9.1.3.3 | 6 | 9.9.5.3 | 11 | 9.9.10.2 | 13 | 9.1.1.1 | 6 | 9.4.3.4 | 11 | 9.9.3.6 | 14 | 9.1.5.2 | 4 | 9.1.3.1 | 2 | 9.1.5.1 | 2 | 9.2.4.4 | 9 | 9.1.3.2 | 4 | 9.1.3.8 | 12 | 9.2.3.6 | 12 |
| 9.8.3.1 | 3 | | | | | | | | | 9.2.3.4 | 9 | | | 9.4.3.3 | 8 | | | | | | | | | | |
| | 32 | | 34 | | 35 | | 8 | | 27 | | 33 | | 35 | | 35 | | 8 | | 31 | | 8 | | 35 | | 31 |

Pilot:

A/C:

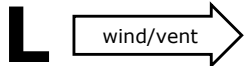

E

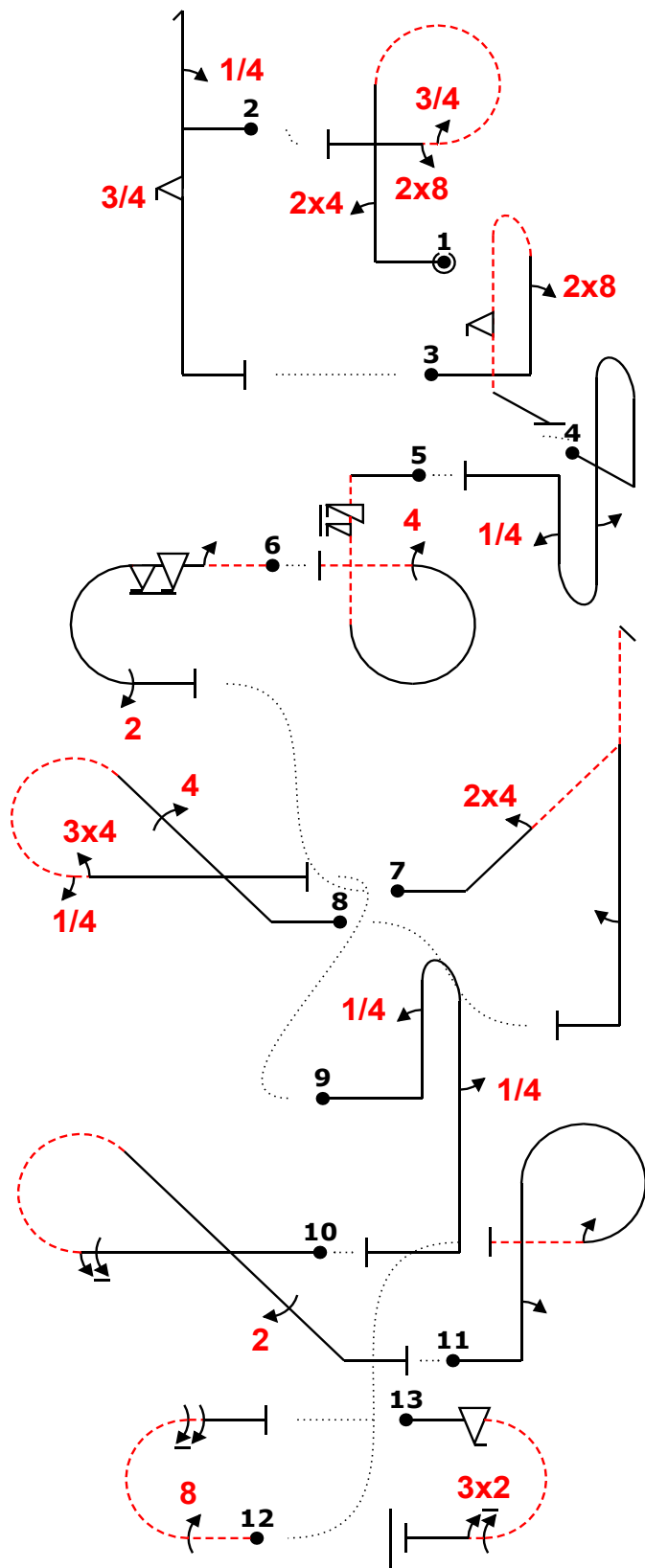

| Fig | Grade | Pos | Remarks |
|-----|-------|-----|---------|
| 1 | . | | |
| 2 | . | | |
| 3 | . | | |
| 4 | . | | |
| 5 | . | | |
| 6 | . | | |
| 7 | . | | |
| 8 | . | | |
| 9 | . | | |
| 10 | . | | |
| 11 | . | | |
| 12 | . | | |
| 13 | . | | |

| | | |
|-------------|----|---|
| Positioning | 30 | . |
|-------------|----|---|

| | | | |
|---------------|--|----------------|--|
| Too Low | | Trg Violation | |
| Too High | | Wing Rocks | |
| Interruptions | | Disqual Fig | |
| Insertions | | Other(note...) | |

"@C" ,24rp3,28 (1,-1) "@E" 4h3f... (-8,0) "@D" 28pb2f (2,0) "@L" bb(,2),4 (-1,0) "@H" 6sirr44- (-1,0) "@A" -2, 6fa22 (-9,14) "@J" ',,24, 'dh...'2...' (10,-7) "@G" 44rc4,34 (3,15) "@L" ,4b,4...' (-1,0) "@F" ,6c....22'''' (1,0) "@L" 2rp2- (11,20) "@I" -88m9 (-5,0) "@B" fa32

| Fig 1 C | K | Fig 2 E | K | Fig 3 D | K | Fig 4 L | K | Fig 5 H | K | Fig 6 A | K | Fig 7 J | K | Fig 8 G | K | Fig 9 L | K | Fig 10 F | K | Fig 11 L | K | Fig 12 I | K | Fig 13 B | K |
|---------|-----------|---------|-----------|----------|-----------|---------|----------|----------|-----------|---------|-----------|---------|-----------|---------|-----------|---------|----------|----------|-----------|----------|----------|----------|-----------|----------|-----------|
| 8.6.4.1 | 14 | 5.2.1.1 | 17 | 8.4.3.1 | 15 | 8.8.2.1 | 19 | 8.6.3.3 | 13 | 7.2.1.4 | 6 | 5.3.2.1 | 24 | 8.5.3.1 | 12 | 8.4.1.1 | 13 | 8.5.7.1 | 12 | 8.6.2.1 | 12 | 7.2.1.2 | 8 | 7.2.2.3 | 8 |
| 9.4.1.2 | 9 | 9.1.1.1 | 6 | 9.8.1.1 | 7 | 9.1.5.2 | 4 | 9.11.1.6 | 3 | 9.1.3.2 | 4 | 9.4.2.2 | 7 | 9.4.2.4 | 13 | 9.1.1.1 | 6 | 9.1.3.6 | 10 | 9.1.1.2 | 8 | 9.8.3.4 | 15 | 9.9.3.4 | 11 |
| 9.1.3.3 | 6 | 9.9.5.3 | 11 | 9.9.10.2 | 13 | 9.1.1.1 | 6 | 9.4.3.4 | 11 | 9.9.3.6 | 14 | 9.1.5.2 | 4 | 9.1.3.1 | 2 | 9.1.5.1 | 2 | 9.2.4.4 | 9 | 9.1.3.2 | 4 | 9.1.3.8 | 12 | 9.2.3.6 | 12 |
| 9.8.3.1 | 3 | | | | | | | | | 9.2.3.4 | 9 | | | 9.4.3.3 | 8 | | | | | | | | | | |
| | 32 | | 34 | | 35 | | 8 | | 27 | | 33 | | 35 | | 35 | | 8 | | 31 | | 8 | | 35 | | 31 |

Pilot:

A/C:



Figure K
352
 Total K
382

| | | |
|-------------|--------|----------|
| Judges Name | | Flight # |
| Signature | Number | |

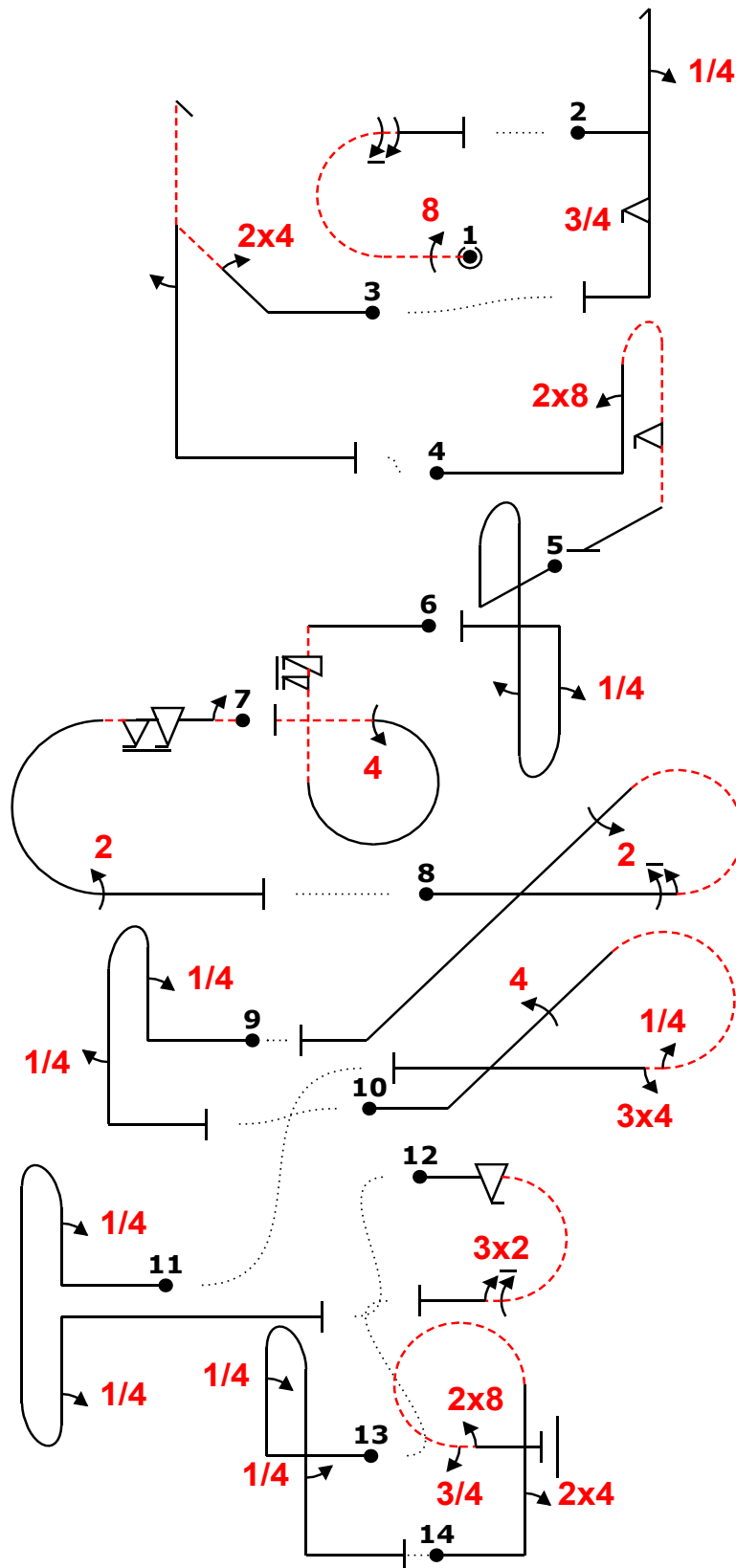
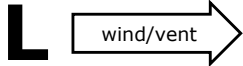

| Fig | Grade | Pos | Remarks |
|-----|-------|-----|---------|
| 1 | . | | |
| 2 | . | | |
| 3 | . | | |
| 4 | . | | |
| 5 | . | | |
| 6 | . | | |
| 7 | . | | |
| 8 | . | | |
| 9 | . | | |
| 10 | . | | |
| 11 | . | | |
| 12 | . | | |
| 13 | . | | |
| 14 | . | | |

Positioning
30

| | | | |
|---------------|--|----------------|--|
| Too Low | | Trg Violation | |
| Too High | | Wing Rocks | |
| Interruptions | | Disqual Fig | |
| Insertions | | Other(note...) | |

"@I" -`88.m9 (-3,0) "@E" 4h'3f. (9,1) "@J" ~24dh2...+~ (-1,1) "@0" /~m+~,8pb2f~ "@L" ~`bb("]"2)'4 "@H" + 6sirp,44- "@A" 4% -`2,6f'a,22+ (-6,0) "@F" ,6c,22... (-1,0) "@L" `4b4 (-6,-1) "@G" 1% `44'rc4,34 (10,14) "@L" /`4bb4'+~+ (-2,-9) "@B" fa32 (-1,10) "@L" `]"4b',]"4' (2,0) "@C" ~24'rp3,8+`

| Fig 1 I | K | Fig 2 E | K | Fig 3 J | K | Fig 4 D | K | Fig 5 L | K | Fig 6 H | K | Fig 7 A | K | Fig 8 F | K | Fig 9 L | K | Fig 10 G | K | Fig 11 L | K | Fig 12 B | K | Fig 13 L | K | Fig 14 C | K |
|---------|-----------|---------|-----------|---------|-----------|----------|-----------|---------|----------|----------|-----------|---------|-----------|---------|-----------|---------|----------|----------|-----------|----------|----------|----------|-----------|----------|----------|----------|-----------|
| 7.2.1.2 | 8 | 5.2.1.1 | 17 | 5.3.2.1 | 24 | 8.4.3.1 | 15 | 8.8.2.1 | 19 | 8.6.3.3 | 13 | 7.2.1.4 | 6 | 8.5.7.1 | 12 | 8.4.1.1 | 13 | 8.5.3.1 | 12 | 8.8.2.1 | 19 | 7.2.2.3 | 8 | 8.4.1.1 | 13 | 8.6.4.1 | 14 |
| 9.8.3.4 | 15 | 9.1.1.1 | 6 | 9.4.2.2 | 7 | 9.8.1.1 | 7 | 9.1.5.2 | 4 | 9.11.1.6 | 3 | 9.1.3.2 | 4 | 9.1.3.6 | 10 | 9.1.1.1 | 6 | 9.4.2.4 | 13 | 9.1.1.1 | 6 | 9.9.3.4 | 11 | 9.1.1.1 | 6 | 9.4.1.2 | 9 |
| 9.1.3.8 | 12 | 9.9.5.3 | 11 | 9.1.5.2 | 4 | 9.9.10.2 | 13 | 9.1.1.1 | 6 | 9.4.3.4 | 11 | 9.9.3.6 | 14 | 9.2.4.4 | 9 | 9.1.5.1 | 2 | 9.1.3.1 | 2 | 9.1.1.1 | 6 | 9.2.3.6 | 12 | 9.1.5.1 | 2 | 9.1.3.3 | 6 |
| | 35 | | 34 | | 35 | | 35 | | 6 | | 27 | | 33 | | 31 | | 6 | | 35 | | 6 | | 31 | | 6 | | 32 |

Pilot:

A/C:

G

wind/vent ← **R**

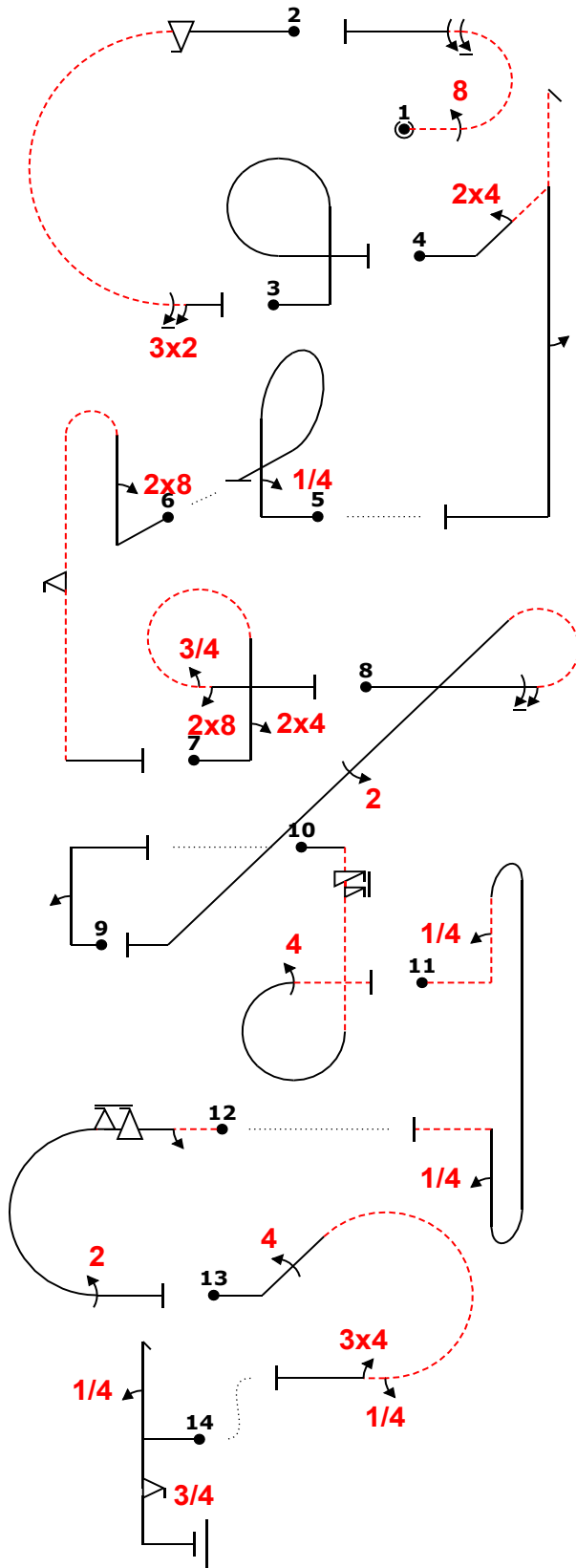

| Fig | Grade | Pos | Remarks |
|-----|-------|-----|---------|
| 1 | . | | |
| 2 | . | | |
| 3 | . | | |
| 4 | . | | |
| 5 | . | | |
| 6 | . | | |
| 7 | . | | |
| 8 | . | | |
| 9 | . | | |
| 10 | . | | |
| 11 | . | | |
| 12 | . | | |
| 13 | . | | |
| 14 | . | | |

Positioning **30** .

| | | | |
|---------------|--|----------------|--|
| Too Low | | Trg Violation | |
| Too High | | Wing Rocks | |
| Interruptions | | Disqual Fig | |
| Insertions | | Other(note...) | |

"@I" -88m9+~ (0,0) "@B" 18% `fa,32+`~ (0,0) "@L" rp~ (0,0) "@J" 24dh...2....+~ (-6,0) "@L" ',4`rp~ (-2,1) "@@
 ",8'`pb...2f... (0,0) "@C" ",24`rp3,8~ (0,0) "@F" -2% ',6c.....'22.....' "@L" '+v2~ (8,0) "@H" '+6s...
 irp44- (0,0) "@L" '-4''bb(.....)' '4- (-11,0) "@A" 7% '-2,6fa22+ (0,0) "@G" 7% '+.....'44`rc4,34+.....
 ~ (-2,5) "@E" 4h3f''

| Fig 1 I | K | Fig 2 B | K | Fig 3 L | K | Fig 4 J | K | Fig 5 L | K | Fig 6 D | K | Fig 7 C | K | Fig 8 F | K | Fig 9 L | K | Fig 10 H | K | Fig 11 L | K | Fig 12 A | K | Fig 13 G | K | Fig 14 E | K |
|---------|-----------|---------|-----------|---------|----------|---------|-----------|---------|----------|----------|-----------|---------|-----------|---------|-----------|---------|----------|----------|-----------|----------|----------|----------|-----------|----------|-----------|----------|-----------|
| 7.2.1.2 | 8 | 7.2.2.3 | 8 | 8.6.1.1 | 11 | 5.3.2.1 | 24 | 8.6.1.1 | 11 | 8.4.3.1 | 15 | 8.6.4.1 | 14 | 8.5.7.1 | 12 | 1.1.6.1 | 12 | 8.6.3.3 | 13 | 8.8.8.2 | 20 | 7.2.1.4 | 6 | 8.5.3.1 | 12 | 5.2.1.1 | 17 |
| 9.8.3.4 | 15 | 9.9.3.4 | 11 | | | 9.4.2.2 | 7 | 9.1.1.1 | 6 | 9.8.1.1 | 7 | 9.4.1.2 | 9 | 9.1.3.6 | 10 | 9.1.1.2 | 8 | 9.1.1.6 | 3 | 9.1.1.1 | 6 | 9.1.3.2 | 4 | 9.4.2.4 | 13 | 9.1.1.1 | 6 |
| 9.1.3.8 | 12 | 9.2.3.6 | 12 | | | 9.1.5.2 | 4 | | | 9.9.10.2 | 13 | 9.1.3.3 | 6 | 9.2.4.4 | 9 | | | 9.4.3.4 | 11 | 9.1.1.1 | 6 | 9.9.3.6 | 14 | 9.1.3.1 | 2 | 9.9.5.3 | 11 |
| | 35 | | 31 | | 6 | | 35 | | 6 | | 35 | | 32 | | 31 | | 6 | | 27 | | 6 | | 33 | | 35 | | 34 |

Pilot:

A/C:

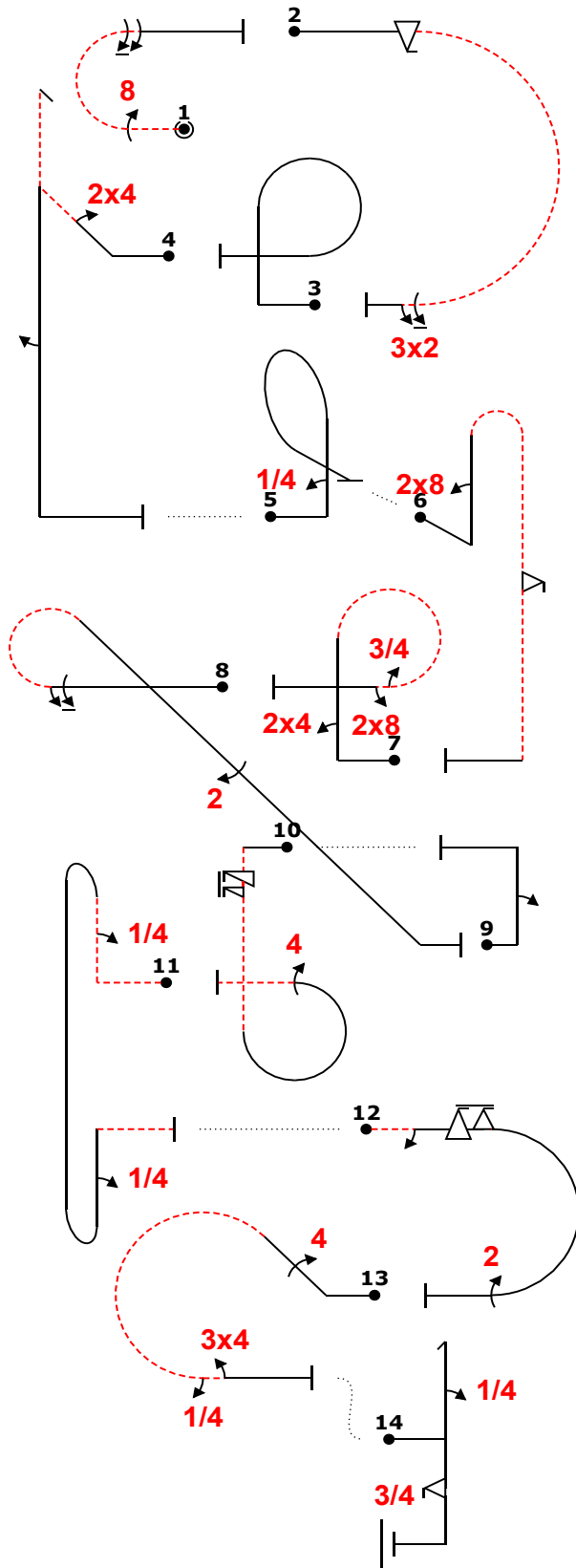
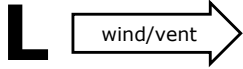

| Fig | Grade | Pos | Remarks |
|-----|-------|-----|---------|
| 1 | . | | |
| 2 | . | | |
| 3 | . | | |
| 4 | . | | |
| 5 | . | | |
| 6 | . | | |
| 7 | . | | |
| 8 | . | | |
| 9 | . | | |
| 10 | . | | |
| 11 | . | | |
| 12 | . | | |
| 13 | . | | |
| 14 | . | | |

| | |
|-------------|---|
| Positioning | . |
| 30 | . |

| | | | |
|---------------|--|----------------|--|
| Too Low | | Trg Violation | |
| Too High | | Wing Rocks | |
| Interruptions | | Disqual Fig | |
| Insertions | | Other(note...) | |

"@I" -88m9+~ (0,0) "@B" 18% `fa,32+`~ (0,0) "@L" rp~ (0,0) "@J" 24dh...2....+~ (-6,0) "@L" ',4`rp~ (-2,1) "@@
 ",8'`pb...2f... (0,0) "@C" ',24`rp3,8~ (0,0) "@F" -2% ',6c.....'22.....' "@L" '+v2~ (8,0) "@H" '+6s...
 irp44- (0,0) "@L" '-4'`bb(.....)' '4- (-11,0) "@A" 7% -'2,6fa22+ (0,0) "@G" 7% '+.....'44`rc4,34+.....
 ' (-2,5) "@E" 4h3f''

| Fig 1 I | K | Fig 2 B | K | Fig 3 L | K | Fig 4 J | K | Fig 5 L | K | Fig 6 D | K | Fig 7 C | K | Fig 8 F | K | Fig 9 L | K | Fig 10 H | K | Fig 11 L | K | Fig 12 A | K | Fig 13 G | K | Fig 14 E | K |
|---------|-----------|---------|-----------|---------|----------|---------|-----------|---------|----------|----------|-----------|---------|-----------|---------|-----------|---------|----------|----------|-----------|----------|----------|----------|-----------|----------|-----------|----------|-----------|
| 7.2.1.2 | 8 | 7.2.2.3 | 8 | 8.6.1.1 | 11 | 5.3.2.1 | 24 | 8.6.1.1 | 11 | 8.4.3.1 | 15 | 8.6.4.1 | 14 | 8.5.7.1 | 12 | 1.1.6.1 | 10 | 8.6.3.3 | 13 | 8.8.8.2 | 20 | 7.2.1.4 | 6 | 8.5.3.1 | 12 | 5.2.1.1 | 17 |
| 9.8.3.4 | 15 | 9.9.3.4 | 11 | | | 9.4.2.2 | 7 | 9.1.1.1 | 6 | 9.8.1.1 | 7 | 9.4.1.2 | 9 | 9.1.3.6 | 10 | 9.1.1.2 | 8 | 9.1.1.6 | 3 | 9.1.1.1 | 6 | 9.1.3.2 | 4 | 9.4.2.4 | 13 | 9.1.1.1 | 6 |
| 9.1.3.8 | 12 | 9.2.3.6 | 12 | | | 9.1.5.2 | 4 | | | 9.9.10.2 | 13 | 9.1.3.3 | 6 | 9.2.4.4 | 9 | | | 9.4.3.4 | 11 | 9.1.1.1 | 6 | 9.9.3.6 | 14 | 9.1.3.1 | 2 | 9.9.5.3 | 11 |
| | 35 | | 31 | | 6 | | 35 | | 6 | | 35 | | 32 | | 31 | | 6 | | 27 | | 6 | | 33 | | 35 | | 34 |

Pilot:

A/C:

H

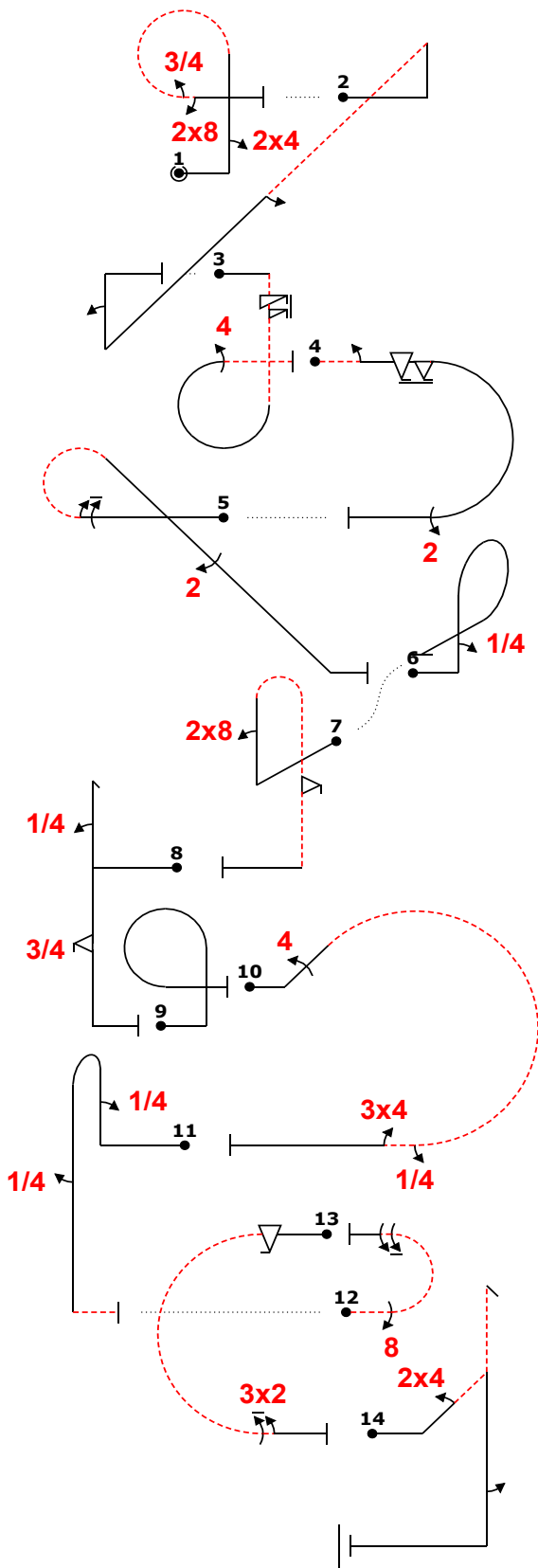
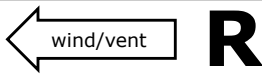

| Fig | Grade | Pos | Remarks |
|-----|-------|-----|---------|
| 1 | . | | |
| 2 | . | | |
| 3 | . | | |
| 4 | . | | |
| 5 | . | | |
| 6 | . | | |
| 7 | . | | |
| 8 | . | | |
| 9 | . | | |
| 10 | . | | |
| 11 | . | | |
| 12 | . | | |
| 13 | . | | |
| 14 | . | | |

Positioning

30

.

Too Low

Trg Violation

Too High

Wing Rocks

Interruptions

Disqual Fig

Insertions

Other(note...)

"@C" `24rp3,8 (3,0) "@L" +`n(....2.....)`2~ (1,0) "@H" 6s`irp44- "@A" 8% -`2,6fa22 (-7,0) "@F" -2% , 6c.....,22.... (0,0) "@L" -1% ,4' rp+~ (-4,6) "@D" ~+8'pb'2f.~ (0,0) "@E" +4h.,3f..' "@L" -1% rp "@G" 17% ` `+`~~~~~44`nc4,34+`~~~~~ (0,0) "@L" ~~,4'b.,4..... (16,0) "@I" -1% -,88m9+` "@B" 13% `fa32+` (0, 0) "@J" 24dh...2.++~ "@L"

| Fig 1 C | K | Fig 2 L | K | Fig 3 H | K | Fig 4 A | K | Fig 5 F | K | Fig 6 L | K | Fig 7 D | K | Fig 8 E | K | Fig 9 L | K | Fig 10 G | K | Fig 11 L | K | Fig 12 I | K | Fig 13 B | K | Fig 14 J | K |
|---------|-----------|----------|----------|---------|-----------|---------|-----------|---------|-----------|---------|----------|----------|-----------|---------|-----------|---------|----------|----------|-----------|----------|----------|----------|-----------|----------|-----------|----------|-----------|
| 8.6.4.1 | 14 | 1.3.12.1 | 21 | 8.6.3.3 | 13 | 7.2.1.4 | 6 | 8.5.7.1 | 12 | 8.6.1.1 | 11 | 8.4.3.1 | 15 | 5.2.1.1 | 17 | 8.6.1.1 | 11 | 8.5.3.1 | 12 | 8.4.2.1 | 14 | 7.2.1.2 | 8 | 7.2.2.3 | 8 | 5.3.2.1 | 24 |
| 9.4.1.2 | 9 | 9.1.4.2 | 4 | 9.1.1.6 | 3 | 9.1.3.2 | 4 | 9.1.3.6 | 10 | 9.1.1.1 | 6 | 9.8.1.1 | 7 | 9.1.1.1 | 6 | | | 9.4.2.4 | 13 | 9.1.1.1 | 6 | 9.8.3.4 | 15 | 9.9.3.4 | 11 | 9.4.2.2 | 7 |
| 9.1.3.3 | 6 | 9.1.1.2 | 8 | 9.4.3.4 | 11 | 9.9.3.6 | 14 | 9.2.4.4 | 9 | | | 9.9.10.2 | 13 | 9.9.5.3 | 11 | | | 9.1.3.1 | 2 | 9.1.5.1 | 2 | 9.1.3.8 | 12 | 9.2.3.6 | 12 | 9.1.5.2 | 4 |
| 9.8.3.1 | 3 | | | | | 9.2.3.4 | 9 | | | | | | | | | | | 9.4.3.3 | 8 | | | | | | | | |
| | 32 | | 6 | | 27 | | 33 | | 31 | | 6 | | 35 | | 34 | | 6 | | 35 | | 6 | | 35 | | 31 | | 35 |

Pilot:

A/C:

| | |
|-------------|--------|
| Judges Name | |
| Signature | Number |

| |
|----------|
| Flight # |
|----------|

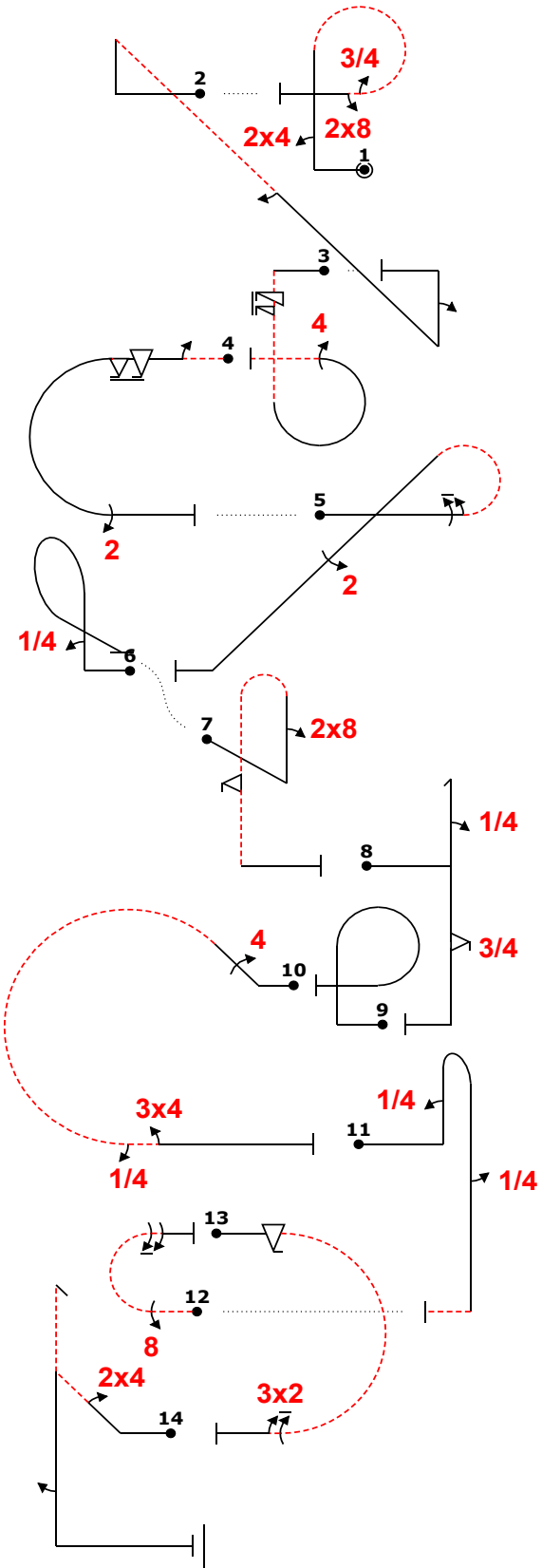
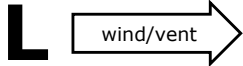

| Fig | Grade | Pos | Remarks |
|-----|-------|-----|---------|
| 1 | . | | |
| 2 | . | | |
| 3 | . | | |
| 4 | . | | |
| 5 | . | | |
| 6 | . | | |
| 7 | . | | |
| 8 | . | | |
| 9 | . | | |
| 10 | . | | |
| 11 | . | | |
| 12 | . | | |
| 13 | . | | |
| 14 | . | | |

| | |
|-------------|---|
| Positioning | . |
| 30 | . |

| | | | |
|---------------|--|----------------|--|
| Too Low | | Trg Violation | |
| Too High | | Wing Rocks | |
| Interruptions | | Disqual Fig | |
| Insertions | | Other(note...) | |

"@C" `24rp3,8 (3,0) "@L" +`n(n(.....2.....) `2~ (1,0) "@H" 6s''irp44- "@A" 8% -`2,6fa22 (-7,0) "@F" -2% ,6C.....',22.... (0,0) "@L" -1% '4' rp+~ (-4,6) "@D" ~+~'8'pb'1'2f.~ (0,0) "@E" +4h.,3f.' "@L" -1% rp "@G" 17% ` `+`.....44` `nc4,34+`..... (0,0) "@L" ~`',4'b.,4...' (16,0) "@I" -1% -,88m9+ "@B" 13% `fa32+` (0,0) "@J" 24dh...'2.+~ "@L"

| Fig 1 C | K | Fig 2 L | K | Fig 3 H | K | Fig 4 A | K | Fig 5 F | K | Fig 6 L | K | Fig 7 D | K | Fig 8 E | K | Fig 9 L | K | Fig 10 G | K | Fig 11 L | K | Fig 12 I | K | Fig 13 B | K | Fig 14 J | K |
|---------|-----------|----------|----------|---------|-----------|---------|-----------|---------|-----------|---------|----------|----------|-----------|---------|-----------|---------|----------|----------|-----------|----------|----------|----------|-----------|----------|-----------|----------|-----------|
| 8.6.4.1 | 14 | 1.3.12.1 | 21 | 8.6.3.3 | 13 | 7.2.1.4 | 6 | 8.5.7.1 | 12 | 8.6.1.1 | 17 | 8.4.3.1 | 15 | 5.2.1.1 | 17 | 8.6.1.1 | 11 | 8.5.3.1 | 12 | 8.4.2.1 | 14 | 7.2.1.2 | 8 | 7.2.2.3 | 8 | 5.3.2.1 | 24 |
| 9.4.1.2 | 9 | 9.1.4.2 | 4 | 9.1.1.6 | 3 | 9.1.3.2 | 4 | 9.1.3.6 | 10 | 9.1.1.1 | 6 | 9.8.1.1 | 7 | 9.1.1.1 | 6 | | | 9.4.2.4 | 13 | 9.1.1.1 | 6 | 9.8.3.4 | 15 | 9.9.3.4 | 11 | 9.4.2.2 | 7 |
| 9.1.3.3 | 6 | 9.1.1.2 | 8 | 9.4.3.4 | 11 | 9.9.3.6 | 14 | 9.2.4.4 | 9 | | | 9.9.10.2 | 13 | 9.9.5.3 | 11 | | | 9.1.3.1 | 2 | 9.1.5.1 | 2 | 9.1.3.8 | 12 | 9.2.3.6 | 12 | 9.1.5.2 | 4 |
| 9.8.3.1 | 3 | | | | | 9.2.3.4 | 9 | | | | | | | | | | | 9.4.3.3 | 8 | | | | | | | | |
| | 32 | | 6 | | 27 | | 33 | | 31 | | 6 | | 35 | | 34 | | 6 | | 35 | | 6 | | 35 | | 31 | | 35 |

Pilot:

A/C:

I ← wind/vent **R**

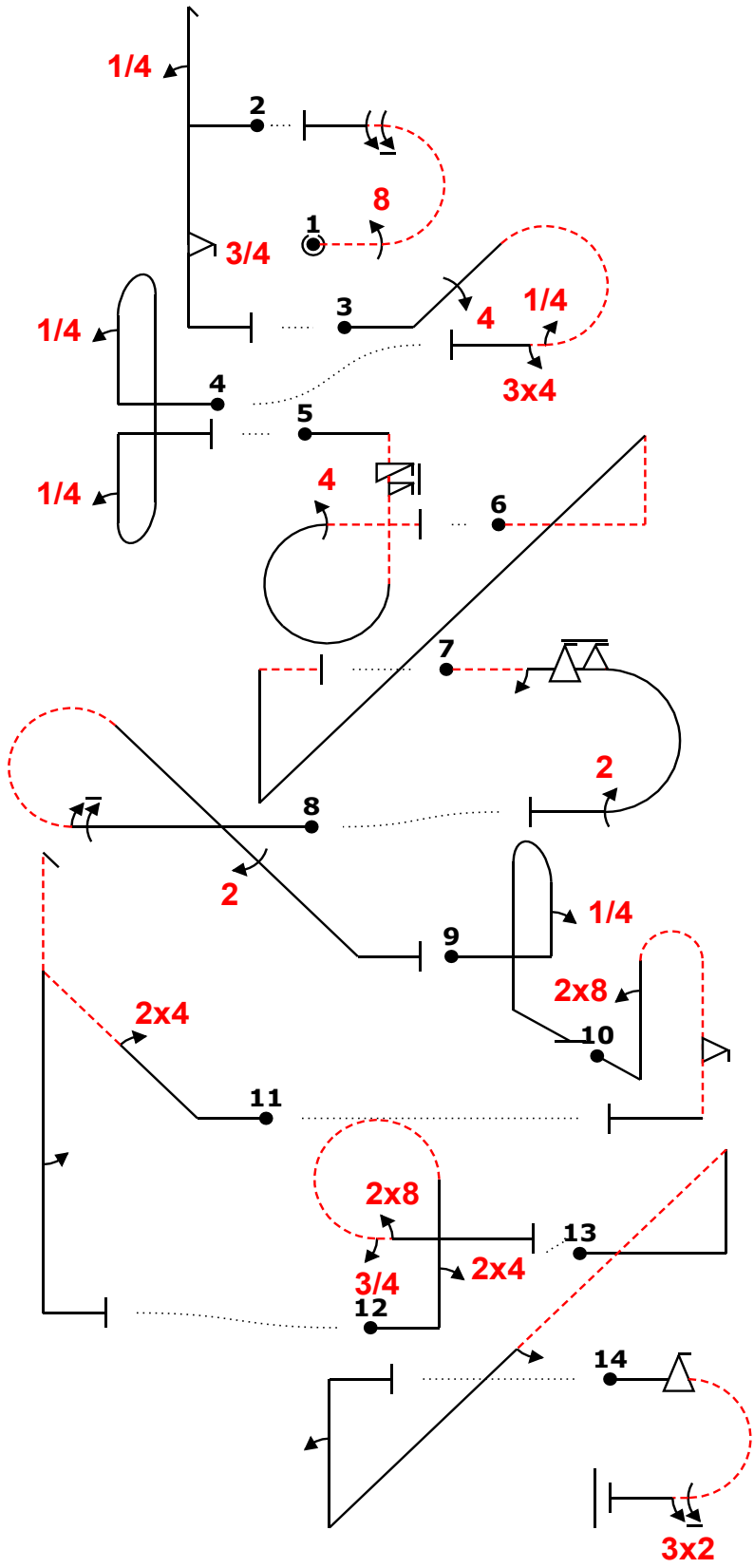

| Fig | Grade | Pos | Remarks |
|-----|-------|-----|---------|
| 1 | . | | |
| 2 | . | | |
| 3 | . | | |
| 4 | . | | |
| 5 | . | | |
| 6 | . | | |
| 7 | . | | |
| 8 | . | | |
| 9 | . | | |
| 10 | . | | |
| 11 | . | | |
| 12 | . | | |
| 13 | . | | |
| 14 | . | | |

Positioning **30** .

| | | | |
|---------------|--|----------------|--|
| Too Low | | Trg Violation | |
| Too High | | Wing Rocks | |
| Interruptions | | Disqual Fig | |
| Insertions | | Other(note...) | |

eu "@I" -88m9 (1,0) "@E" 4h.3f. (2,0) "@G"44rc,4,34+ (-11,4) "@L" 4bb4 (2,0) "@H" ~6sirr44- (1,0) "@L" ~~~~~pn(.....)'-(4,0) "@A" 2% -2,6fa,22 (-10,1) "@F" ,6c....,22 "@L" /'";,4b "@D" ~~~+8pb2f (-18,0) "@J" .,24.dh....2..' (13,1) "@C" ,24`rp,3,8+ (-1,1) "@L" ~~~+`n(.....)'2 (10,0) "@B" fa32

| Fig 1 I | K | Fig 2 E | K | Fig 3 G | K | Fig 4 L | K | Fig 5 H | K | Fig 6 L | K | Fig 7 A | K | Fig 8 F | K | Fig 9 L | K | Fig 10 D | K | Fig 11 J | K | Fig 12 C | K | Fig 13 L | K | Fig 14 B | K |
|---------|-----------|---------|-----------|---------|-----------|---------|----------|----------|-----------|---------|----------|---------|-----------|---------|-----------|---------|----------|----------|-----------|----------|-----------|----------|-----------|----------|----------|-----------|----|
| 7.2.1.2 | 8 | 5.2.1.1 | 17 | 8.5.3.1 | 12 | 8.8.2.1 | 19 | 8.6.3.3 | 13 | 1.3.9.2 | 24 | 7.2.1.4 | 6 | 8.5.7.1 | 12 | 8.4.1.1 | 13 | 8.4.3.1 | 15 | 5.3.2.1 | 24 | 8.6.4.1 | 14 | 1.3.12.1 | 21 | 7.2.2.3 | 8 |
| 9.8.3.4 | 15 | 9.1.1.1 | 6 | 9.4.2.4 | 13 | 9.1.1.1 | 6 | 9.11.1.6 | 3 | | | 9.1.3.2 | 4 | 9.1.3.6 | 10 | 9.1.1.1 | 6 | 9.8.1.1 | 7 | 9.4.2.2 | 7 | 9.4.1.2 | 9 | 9.1.4.2 | 4 | 9.9.3.4 | 11 |
| 9.1.3.8 | 12 | 9.9.5.3 | 11 | 9.1.3.1 | 2 | 9.1.1.1 | 6 | 9.4.3.4 | 11 | | | 9.9.3.6 | 14 | 9.2.4.4 | 9 | | | 9.9.10.2 | 13 | 9.1.5.2 | 4 | 9.1.3.3 | 6 | 9.1.1.2 | 8 | 9.2.3.6 | 12 |
| | 35 | | 34 | | 35 | | 6 | | 27 | | 6 | | 33 | | 31 | | 6 | | 35 | | 35 | | 32 | | 6 | 31 | |

Pilot:

A/C:

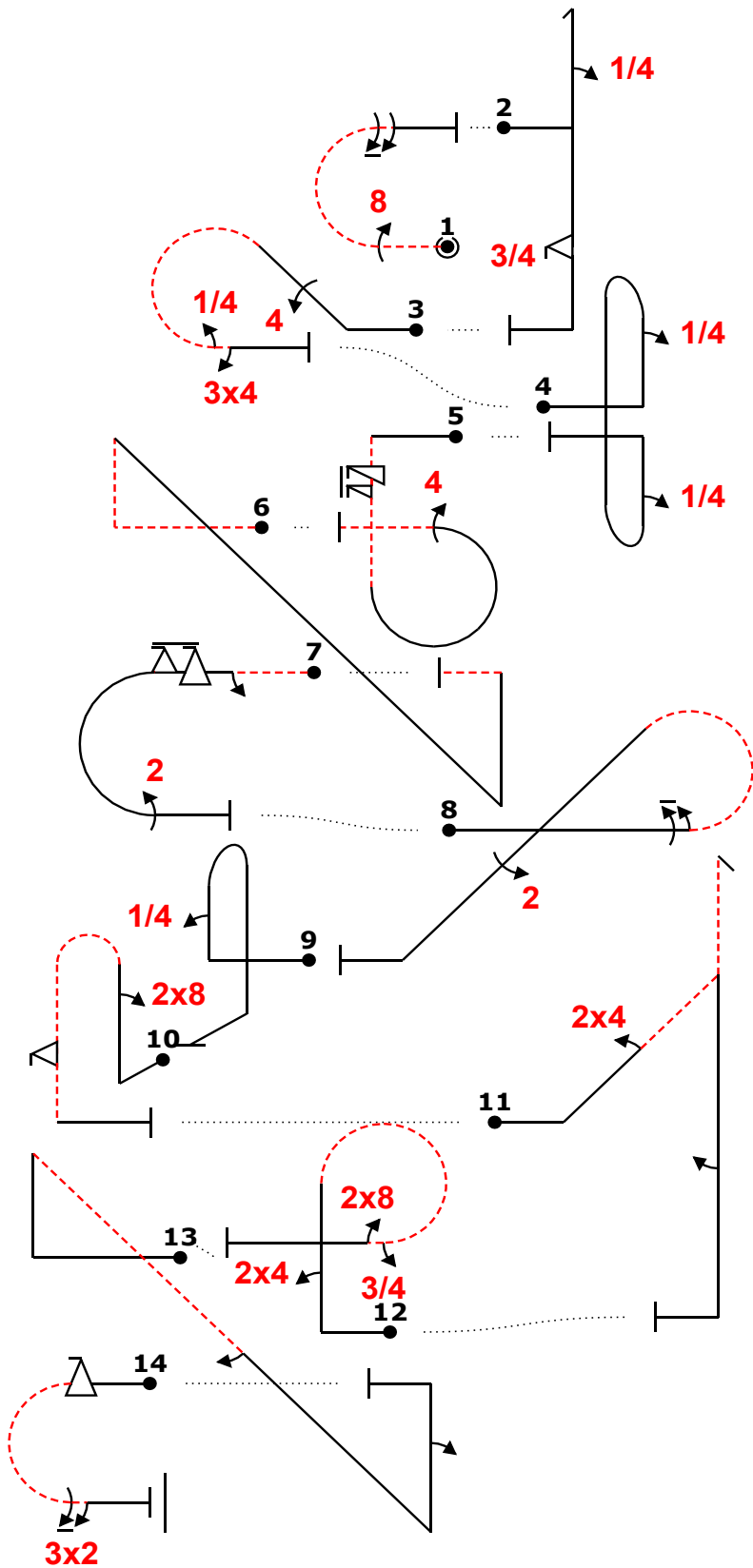
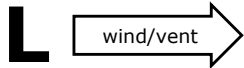

| Fig | Grade | Pos | Remarks |
|-----|-------|-----|---------|
| 1 | . | | |
| 2 | . | | |
| 3 | . | | |
| 4 | . | | |
| 5 | . | | |
| 6 | . | | |
| 7 | . | | |
| 8 | . | | |
| 9 | . | | |
| 10 | . | | |
| 11 | . | | |
| 12 | . | | |
| 13 | . | | |
| 14 | . | | |

Positioning 30 .

| | | | |
|---------------|--|----------------|--|
| Too Low | | Trg Violation | |
| Too High | | Wing Rocks | |
| Interruptions | | Disqual Fig | |
| Insertions | | Other(note...) | |

eu "@I" -88m9 (1,0) "@E" 4h.*3f. (2,0) "@G"44rc,4,34+ (-11,4) "@L" 4bb4 (2,0) "@H" ~6sirr44- (1,0) "@L" ~~~~~pn(.....)'- (4,0) "@A" 2% -2,6fa,22 (-10,1) "@F" ,6c.....,22 "@L" /'";4b "@D" ~~~+8pb2f (-18,0) "@J" .,24.dh...2...' (13,1) "@C" ,24`rp,3,8+ (-1,1) "@L" ~~~'n(...)'2.....'2 (10,0) "@B" fa32

| Fig 1 I | K | Fig 2 E | K | Fig 3 G | K | Fig 4 L | K | Fig 5 H | K | Fig 6 L | K | Fig 7 A | K | Fig 8 F | K | Fig 9 L | K | Fig 10 D | K | Fig 11 J | K | Fig 12 C | K | Fig 13 L | K | Fig 14 B | K |
|---------|----|---------|----|---------|----|---------|----|----------|----|---------|----|---------|----|---------|----|---------|----|----------|----|----------|----|----------|----|----------|----|----------|----|
| 7.2.1.2 | 8 | 5.2.1.1 | 17 | 8.5.3.1 | 12 | 8.8.2.1 | 19 | 8.6.3.3 | 13 | 1.3.9.2 | 24 | 7.2.1.4 | 6 | 8.5.7.1 | 12 | 8.4.1.1 | 13 | 8.4.3.1 | 15 | 5.3.2.1 | 24 | 8.6.4.1 | 14 | 1.3.12.1 | 21 | 7.2.2.3 | 8 |
| 9.8.3.4 | 15 | 9.1.1.1 | 6 | 9.4.2.4 | 13 | 9.1.1.1 | 6 | 9.11.1.6 | 3 | | | 9.1.3.2 | 4 | 9.1.3.6 | 10 | 9.1.1.1 | 6 | 9.8.1.1 | 7 | 9.4.2.2 | 7 | 9.4.1.2 | 9 | 9.1.4.2 | 4 | 9.9.3.4 | 11 |
| 9.1.3.8 | 12 | 9.9.5.3 | 11 | 9.1.3.1 | 2 | 9.1.1.1 | 6 | 9.4.3.4 | 11 | | | 9.9.3.6 | 14 | 9.2.4.4 | 9 | | | 9.9.10.2 | 13 | 9.1.5.2 | 4 | 9.1.3.3 | 6 | 9.1.1.2 | 8 | 9.2.3.6 | 12 |
| | 35 | | 34 | | 35 | | 6 | | 27 | | 6 | | 33 | | 31 | | 6 | | 35 | | 35 | | 32 | | 6 | 31 | |

Pilot:

A/C:

J ← wind/vent **R**

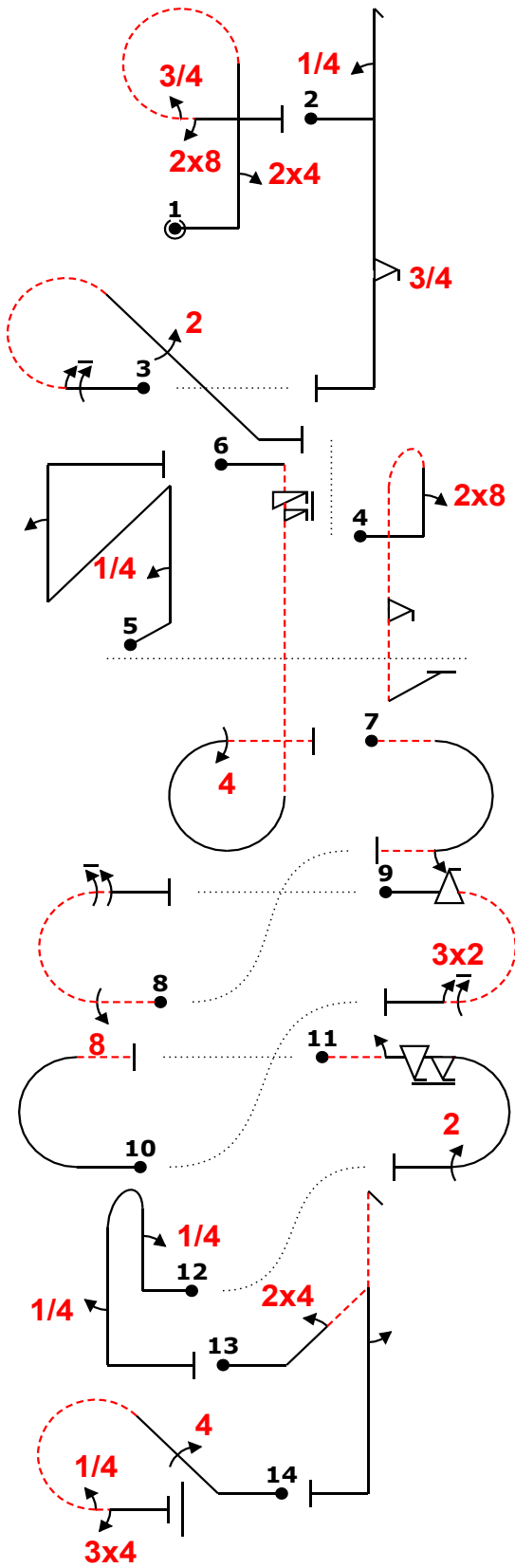

| Fig | Grade | Pos | Remarks |
|-----|-------|-----|---------|
| 1 | . | | |
| 2 | . | | |
| 3 | . | | |
| 4 | . | | |
| 5 | . | | |
| 6 | . | | |
| 7 | . | | |
| 8 | . | | |
| 9 | . | | |
| 10 | . | | |
| 11 | . | | |
| 12 | . | | |
| 13 | . | | |
| 14 | . | | |

Positioning **30** .

| | | | |
|---------------|--|----------------|--|
| Too Low | | Trg Violation | |
| Too High | | Wing Rocks | |
| Interruptions | | Disqual Fig | |
| Insertions | | Other(note...) | |

"@C" ,24rp3,28 "@E" 4h.. '3f.. (-8,0) "@F" ,6c..22+ [0,7] "@D" ,8pb.2f' '^ [-25,0] "@L" 4pn2+~
 "@H" 2> 6s.... 'irp,44- "@L" 2> -a2- (-11,11) "@I" -88m9 (11,0) "@B" fa,32 (-13,12) "@L" m- (9,0) "@A" -2,6fa,22
 (-10,9) "@L" ,4b,4 "@J" 24dh(^)2.... "@G" ,44rc4,34+

| Fig 1 C | K | Fig 2 E | K | Fig 3 F | K | Fig 4 D | K | Fig 5 L | K | Fig 6 H | K | Fig 7 L | K | Fig 8 I | K | Fig 9 B | K | Fig 10 L | K | Fig 11 A | K | Fig 12 L | K | Fig 13 J | K | Fig 14 G | K |
|---------|-----------|---------|-----------|---------|-----------|----------|-----------|----------|----------|----------|-----------|---------|----------|---------|-----------|---------|-----------|----------|----------|----------|-----------|----------|----------|----------|-----------|----------|-----------|
| 8.6.4.1 | 14 | 5.2.1.1 | 17 | 8.5.7.1 | 12 | 8.4.3.1 | 15 | 1.3.13.1 | 22 | 8.6.3.3 | 13 | 7.2.2.4 | 7 | 7.2.1.2 | 8 | 7.2.2.3 | 8 | 7.2.1.1 | 6 | 7.2.1.4 | 6 | 8.4.1.1 | 13 | 5.3.2.1 | 24 | 8.5.3.1 | 12 |
| 9.4.1.2 | 9 | 9.1.1.1 | 6 | 9.1.3.6 | 10 | 9.8.1.1 | 7 | 9.1.1.1 | 6 | 9.11.1.6 | 3 | 9.1.3.2 | 4 | 9.8.3.4 | 15 | 9.9.3.4 | 11 | | | 9.1.3.2 | 4 | 9.1.1.1 | 6 | 9.4.2.2 | 7 | 9.4.2.4 | 13 |
| 9.1.3.3 | 6 | 9.9.5.3 | 11 | 9.2.4.4 | 9 | 9.9.10.2 | 13 | 9.1.1.2 | 8 | 9.4.3.4 | 11 | | | 9.1.3.8 | 12 | 9.2.3.6 | 12 | | | 9.9.3.6 | 14 | 9.1.5.1 | 2 | 9.1.5.2 | 4 | 9.1.3.1 | 2 |
| 9.8.3.1 | 3 | | | | | | | | | | | | | | | | | | | 9.2.3.4 | 9 | | | | | 9.4.3.3 | 8 |
| | 32 | | 34 | | 31 | | 35 | | 6 | | 27 | | 6 | | 35 | | 31 | | 6 | | 33 | | 6 | | 35 | | 35 |

Pilot:

A/C:



Figure K
352
 Total K
382

| | | |
|-------------|--------|----------|
| Judges Name | | Flight # |
| Signature | Number | |

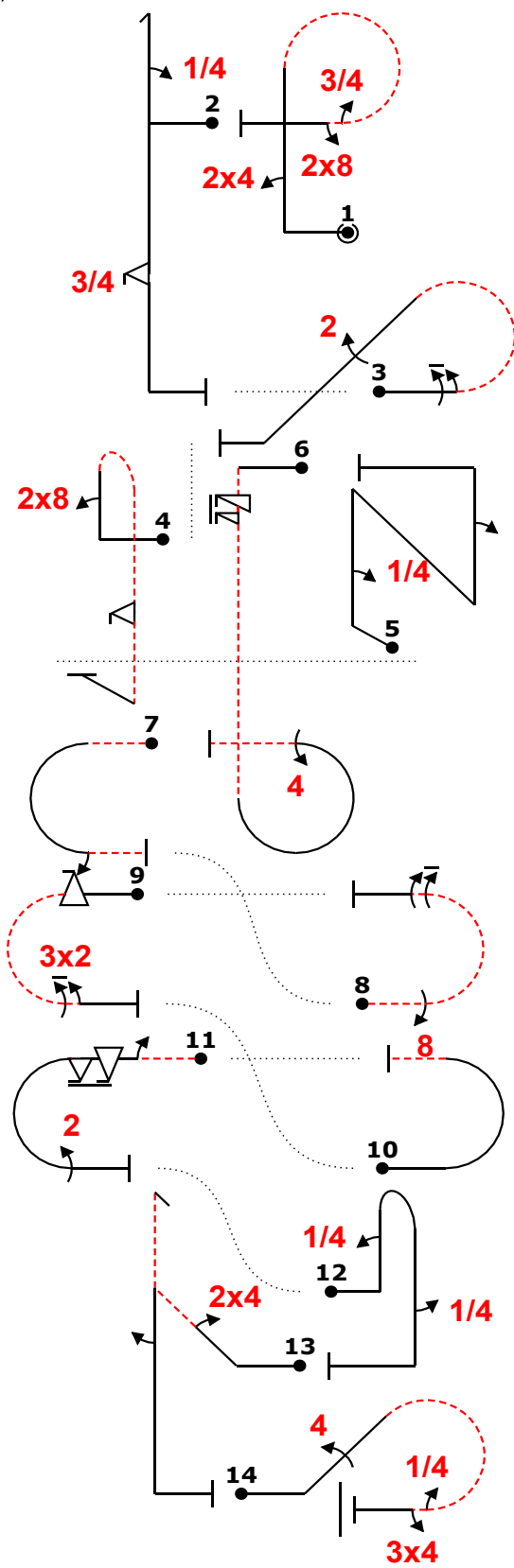
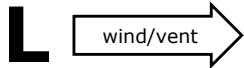

| Fig | Grade | Pos | Remarks |
|-----|-------|-----|---------|
| 1 | . | | |
| 2 | . | | |
| 3 | . | | |
| 4 | . | | |
| 5 | . | | |
| 6 | . | | |
| 7 | . | | |
| 8 | . | | |
| 9 | . | | |
| 10 | . | | |
| 11 | . | | |
| 12 | . | | |
| 13 | . | | |
| 14 | . | | |

| | |
|-------------|---|
| Positioning | . |
| 30 | |

| | | | |
|---------------|--|----------------|--|
| Too Low | | Trg Violation | |
| Too High | | Wing Rocks | |
| Interruptions | | Disqual Fig | |
| Insertions | | Other(note...) | |

"@C" ,24rp3,28 "@E" 4h..3f.. (-8,0) "@F"6c.22+ [0,7] "@D"8pb.2f'..' [-25,0] "@L" 4pn2+~
 "@H" 2> 6s....'irp,44- "@L" 2> -a2- (-11,11) "@I" -88m9 (11,0) "@B" fa,32 (-13,12) "@L" m- (9,0) "@A" -2,6fa,22
 (-10,9) "@L"4b,4 "@J" 24dh(^)2.... "@G"44rc4,34+

| Fig 1 C | K | Fig 2 E | K | Fig 3 F | K | Fig 4 D | K | Fig 5 L | K | Fig 6 H | K | Fig 7 L | K | Fig 8 I | K | Fig 9 B | K | Fig 10 L | K | Fig 11 A | K | Fig 12 L | K | Fig 13 J | K | Fig 14 G | K |
|---------|-----------|---------|-----------|---------|-----------|----------|-----------|----------|----------|---------|-----------|---------|----------|---------|-----------|---------|-----------|----------|----------|----------|----|----------|---|----------|-----------|----------|-----------|
| 8.6.4.1 | 14 | 5.2.1.1 | 17 | 8.5.7.1 | 12 | 8.4.3.1 | 15 | 1.3.13.1 | 22 | 8.6.3.3 | 13 | 7.2.2.4 | 7 | 9.8.3.4 | 15 | 9.9.3.4 | 11 | 7.2.1.1 | 6 | 9.1.3.2 | 4 | 9.1.1.1 | 6 | 9.4.2.2 | 7 | 9.4.2.4 | 13 |
| 9.4.1.2 | 9 | 9.1.1.1 | 6 | 9.1.3.6 | 10 | 9.8.1.1 | 7 | 9.1.1.1 | 6 | 9.1.1.6 | 3 | 9.1.3.2 | 4 | 9.1.3.8 | 12 | 9.2.3.6 | 12 | | | 9.9.3.6 | 14 | 9.1.5.1 | 2 | 9.1.5.2 | 4 | 9.1.3.1 | 2 |
| 9.1.3.3 | 6 | 9.9.5.3 | 11 | 9.2.4.4 | 9 | 9.9.10.2 | 13 | 9.1.1.2 | 8 | 9.4.3.4 | 11 | | | | | | | | | 9.2.3.4 | 9 | | | | | 9.4.3.3 | 8 |
| 9.8.3.1 | 3 | | | | | | | | | | | | | | | | | | | | | | | | | | |
| | 32 | | 34 | | 31 | | 35 | | 6 | | 27 | | 6 | | 35 | | 31 | | 6 | | | | | | 35 | | 35 |

Pilot:

A/C:

K

wind/vent ← **R**

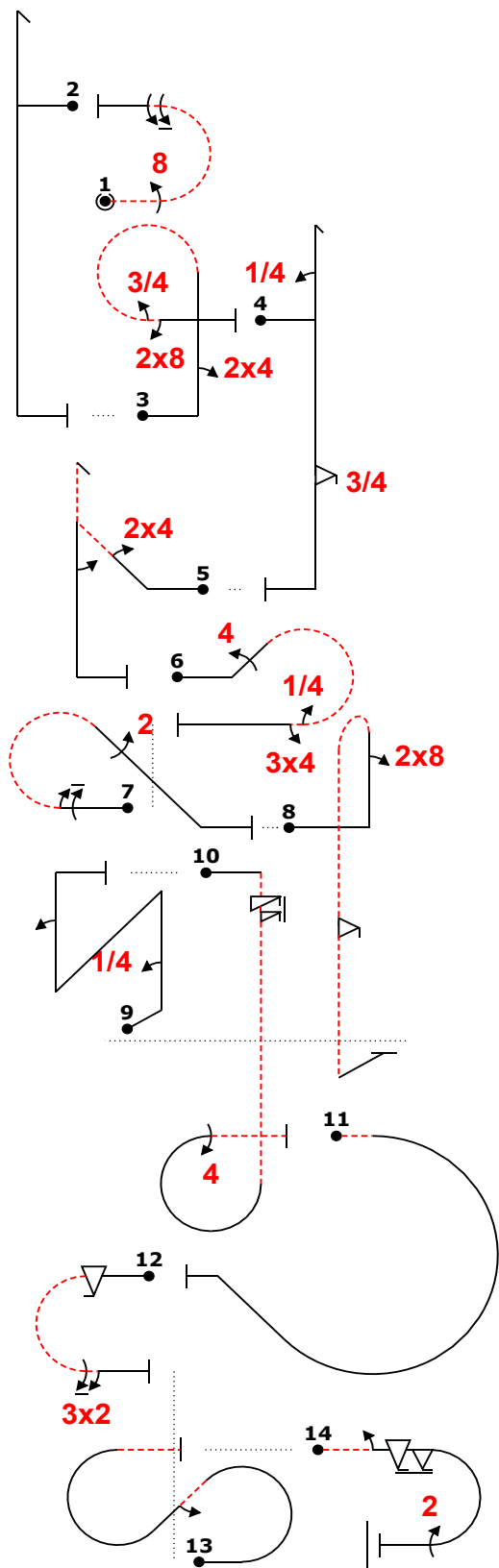

| Fig | Grade | Pos | Remarks |
|-----|-------|-----|---------|
| 1 | . | | |
| 2 | . | | |
| 3 | . | | |
| 4 | . | | |
| 5 | . | | |
| 6 | . | | |
| 7 | . | | |
| 8 | . | | |
| 9 | . | | |
| 10 | . | | |
| 11 | . | | |
| 12 | . | | |
| 13 | . | | |
| 14 | . | | |

Positioning **30** .

| | | | |
|---------------|--|----------------|--|
| Too Low | | Trg Violation | |
| Too High | | Wing Rocks | |
| Interruptions | | Disqual Fig | |
| Insertions | | Other(note...) | |

"@I" -88m9 "@L" h.....' (2,0) "@C" ,24rp3,28 "@E" 4h...3f... (-1,0) "@J" ,24dh(.....)2... "@G" 2>44' rc,4,34+ [0,7] "@F" ,6c22 (-1,0) "@D" ,8pb...2f...'^ [-24,0] "@L" 4pn2 (4,0) "@H" 6s.....'irp ,44- "@L" 15% 2> -ic + "@B" > fa,32 [0,16] "@L"ac(2)- (7,0) "@A" -2,6fa,22

| Fig 1 I | K | Fig 2 L | K | Fig 3 C | K | Fig 4 E | K | Fig 5 J | K | Fig 6 G | K | Fig 7 F | K | Fig 8 D | K | Fig 9 L | K | Fig 10 H | K | Fig 11 L | K | Fig 12 B | K | Fig 13 L | K | Fig 14 A | K |
|---------|-----------|---------|----------|---------|-----------|---------|-----------|---------|-----------|---------|-----------|---------|-----------|----------|-----------|----------|----------|----------|-----------|----------|----------|----------|-----------|----------|----------|----------|-----------|
| 7.2.1.2 | 8 | 5.2.1.1 | 17 | 8.6.4.1 | 14 | 5.2.1.1 | 17 | 5.3.2.1 | 24 | 8.5.3.1 | 12 | 8.5.7.1 | 12 | 8.4.3.1 | 15 | 1.3.13.1 | 22 | 8.6.3.3 | 13 | 8.5.5.4 | 10 | 7.2.2.3 | 8 | 7.5.2.1 | 15 | 7.2.1.4 | 6 |
| 9.8.3.4 | 15 | | | 9.4.1.2 | 9 | 9.1.1.1 | 6 | 9.4.2.2 | 7 | 9.4.2.4 | 13 | 9.1.3.6 | 10 | 9.8.1.1 | 7 | 9.1.1.1 | 6 | 9.1.1.6 | 3 | | | 9.9.3.4 | 11 | 9.1.4.2 | 4 | 9.1.3.2 | 4 |
| 9.1.3.8 | 12 | | | 9.1.3.3 | 6 | 9.9.5.3 | 11 | 9.1.5.2 | 4 | 9.1.3.1 | 2 | 9.2.4.4 | 9 | 9.9.10.2 | 13 | 9.1.1.2 | 8 | 9.4.3.4 | 11 | | | 9.2.3.6 | 12 | | | 9.9.3.6 | 14 |
| | | | | 9.8.3.1 | 3 | | | | | 9.4.3.3 | 8 | | | | | | | | | | | | | | | 9.2.3.4 | 9 |
| | 35 | | 6 | | 32 | | 34 | | 35 | | 35 | | 31 | | 35 | | 6 | | 27 | | 6 | | 31 | | 6 | | 33 |

Pilot:

A/C:

Team: **CZE**

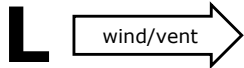

K

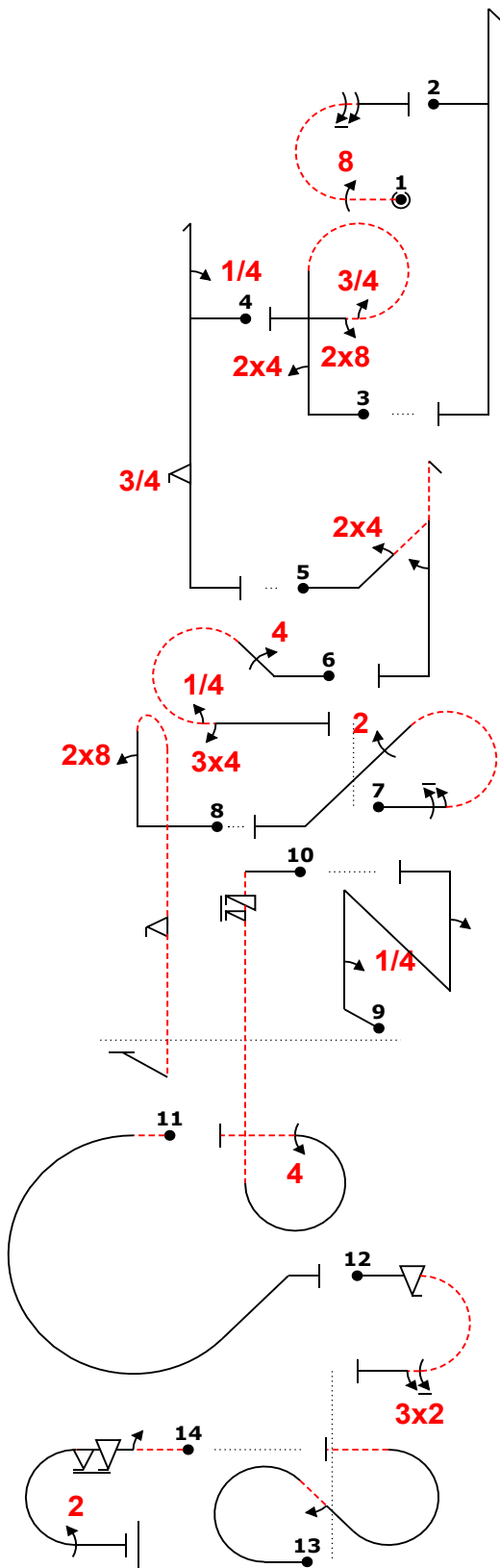

| Fig | Grade | Pos | Remarks |
|-----|-------|-----|---------|
| 1 | . | | |
| 2 | . | | |
| 3 | . | | |
| 4 | . | | |
| 5 | . | | |
| 6 | . | | |
| 7 | . | | |
| 8 | . | | |
| 9 | . | | |
| 10 | . | | |
| 11 | . | | |
| 12 | . | | |
| 13 | . | | |
| 14 | . | | |

Positioning **30** .

| | | | |
|---------------|--|----------------|--|
| Too Low | | Trg Violation | |
| Too High | | Wing Rocks | |
| Interruptions | | Disqual Fig | |
| Insertions | | Other(note...) | |

"@I" -88m9 "@L" h.....' (2,0) "@C" ,24rp3,28 "@E" 4h...3f...' (-1,0) "@J" ,24dh(.....)2...' "@G" 2>44' ..rc,4,34+..... [0,7] "@F"6c22 (-1,0) "@D" ,8pb...2f...' '^ [-24,0] "@L" 4pn2 (4,0) "@H" 6s.....irp ..44- "@L" 15% 2> -.....ic+ "@B" > fa,32 [0,16] "@L"ac(2)-..... (7,0) "@A" -2,6fa,22

| Fig 1 I | K | Fig 2 L | K | Fig 3 C | K | Fig 4 E | K | Fig 5 J | K | Fig 6 G | K | Fig 7 F | K | Fig 8 D | K | Fig 9 L | K | Fig 10 H | K | Fig 11 L | K | Fig 12 B | K | Fig 13 L | K | Fig 14 A | K |
|---------|-----------|---------|----------|---------|-----------|---------|-----------|---------|-----------|---------|-----------|---------|-----------|----------|-----------|----------|----------|----------|-----------|----------|----------|----------|-----------|----------|----------|----------|-----------|
| 7.2.1.2 | 8 | 5.2.1.1 | 17 | 8.6.4.1 | 14 | 5.2.1.1 | 17 | 5.3.2.1 | 24 | 8.5.3.1 | 12 | 8.5.7.1 | 12 | 8.4.3.1 | 15 | 1.3.13.1 | 22 | 8.6.3.3 | 13 | 8.5.5.4 | 10 | 7.2.2.3 | 8 | 7.5.2.1 | 15 | 7.2.1.4 | 6 |
| 9.8.3.4 | 15 | | | 9.4.1.2 | 9 | 9.1.1.1 | 6 | 9.4.2.2 | 7 | 9.4.2.4 | 13 | 9.1.3.6 | 10 | 9.8.1.1 | 7 | 9.1.1.1 | 6 | 9.1.1.6 | 3 | | | 9.9.3.4 | 11 | 9.1.4.2 | 4 | 9.1.3.2 | 4 |
| 9.1.3.8 | 12 | | | 9.1.3.3 | 6 | 9.9.5.3 | 11 | 9.1.5.2 | 4 | 9.1.3.1 | 2 | 9.2.4.4 | 9 | 9.9.10.2 | 13 | 9.1.1.2 | 8 | 9.4.3.4 | 11 | | | 9.2.3.6 | 12 | | | 9.9.3.6 | 14 |
| | | | | 9.8.3.1 | 3 | | | | | 9.4.3.3 | 8 | | | | | | | | | | | | | | | 9.2.3.4 | 9 |
| | 35 | | 6 | | 32 | | 34 | | 35 | | 35 | | 31 | | 35 | | 6 | | 27 | | 6 | | 31 | | 6 | | 33 |

Pilot:

A/C:

Team: CZE